

Oláj Ibolya

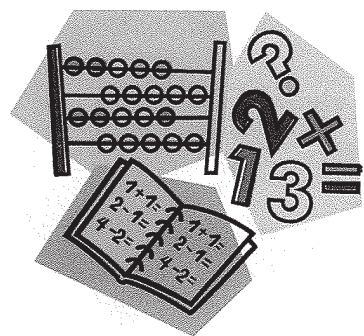
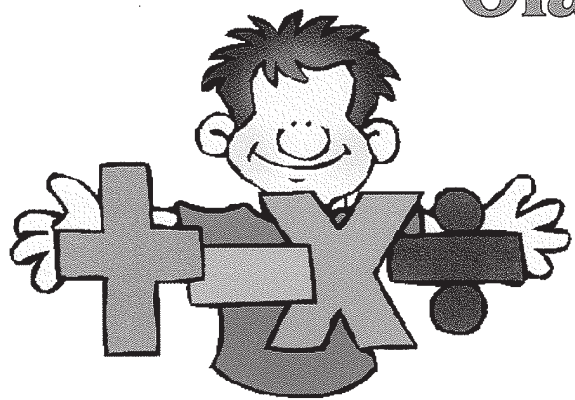

# MATEMATIKA

## A 20-AS SZÁMKÖRBE

A kiegészítő tagozat 2. osztálya számára

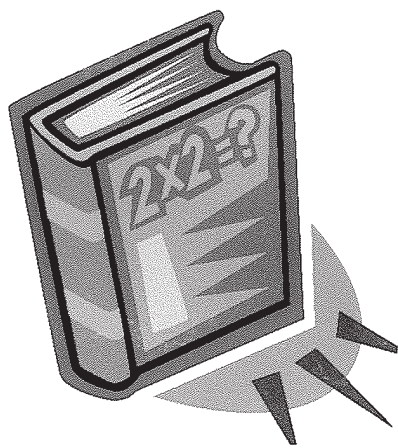

Árgus  
Újvidék - 2010

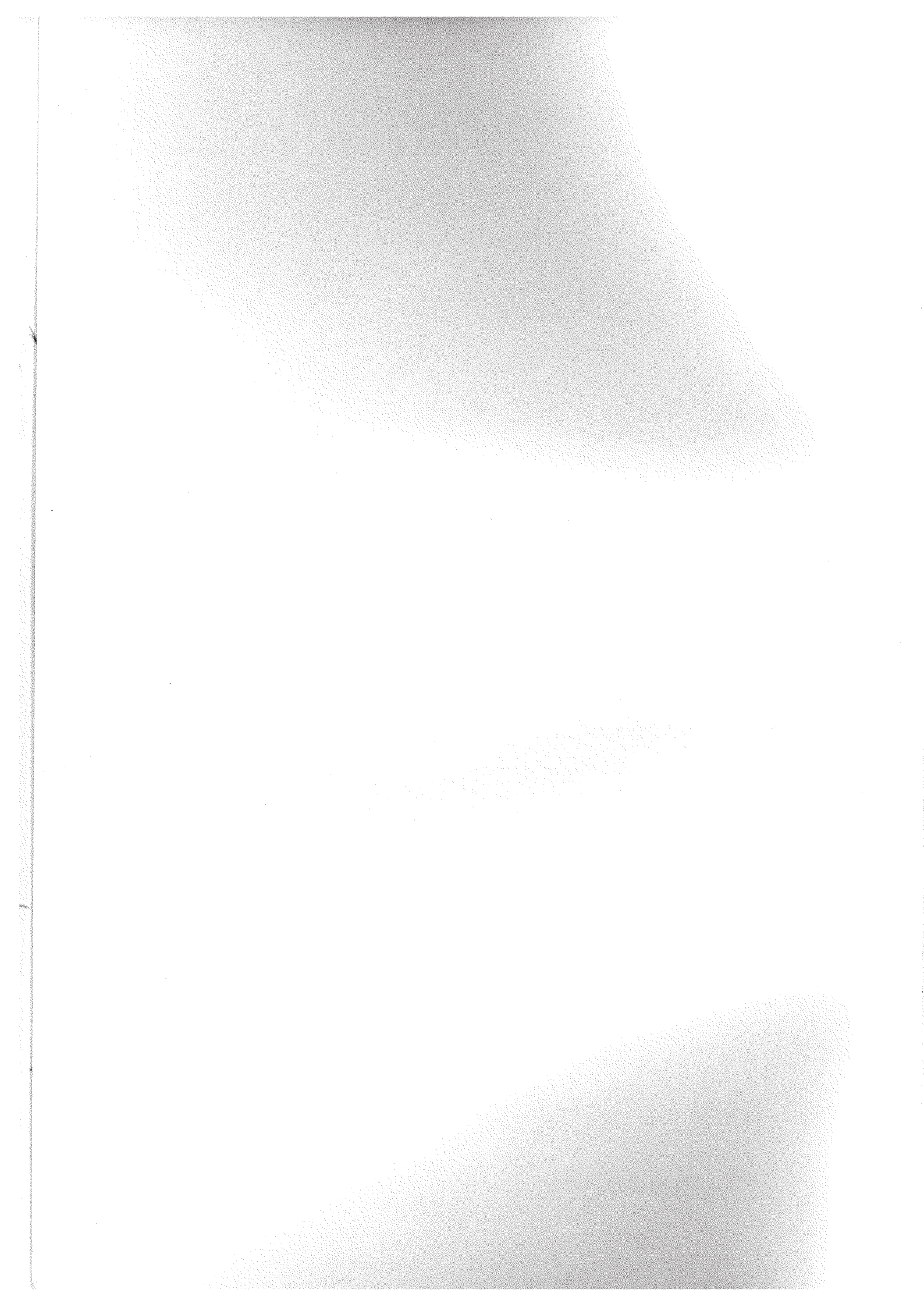

Oláj Ibolya

# MATEMATIKA

## A 20-AS SZÁMKÖRBE

A kiegészítő tagozat 2. osztálya számára

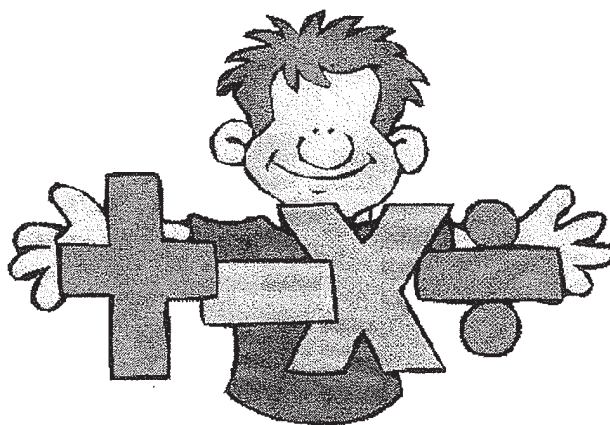

Árgus

Újvidék - 2010

# MATEMATIKA

A 20-AS SZÁMKÖRBEN

A kisegítő tagozat 2. osztálya számára

Írta: Oláj Ibolya

Szakkvéleményező: Galusz Gabriella

Szerkesztő: Muhi Béla

Tel. 064 266-00-51

Ez a kiadvány a magyarországi Szülőföld Alap támogatásával jelenik meg

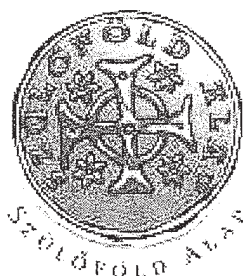

Szervezés: Vajdasági Magyar Tankönyv Tanács

Kiadó: Árgus – Újvidék  
Nyomda: VERZAL – Újvidék

## A kiadvány katalógizálása

CIP – Каталогизација у публикацији  
Библиотека Матице српске, Нови Сад

37. 016 : 51 – 028.31 (075 . 2) (076.1)

**OLÁJ, Ibolya**

Matematika a 20-as számkörben : a kisegítő tagozat 2. osztálya számára / Oláj Ibolya. – Újvidék : Árgus, 2010  
(Újvidék : Verzal). - 109 str. : ilustr. ; 30 cm

ISBN 978-86-87633-21-6

COBISS.SR · ID 253451015

# Szorgalmas

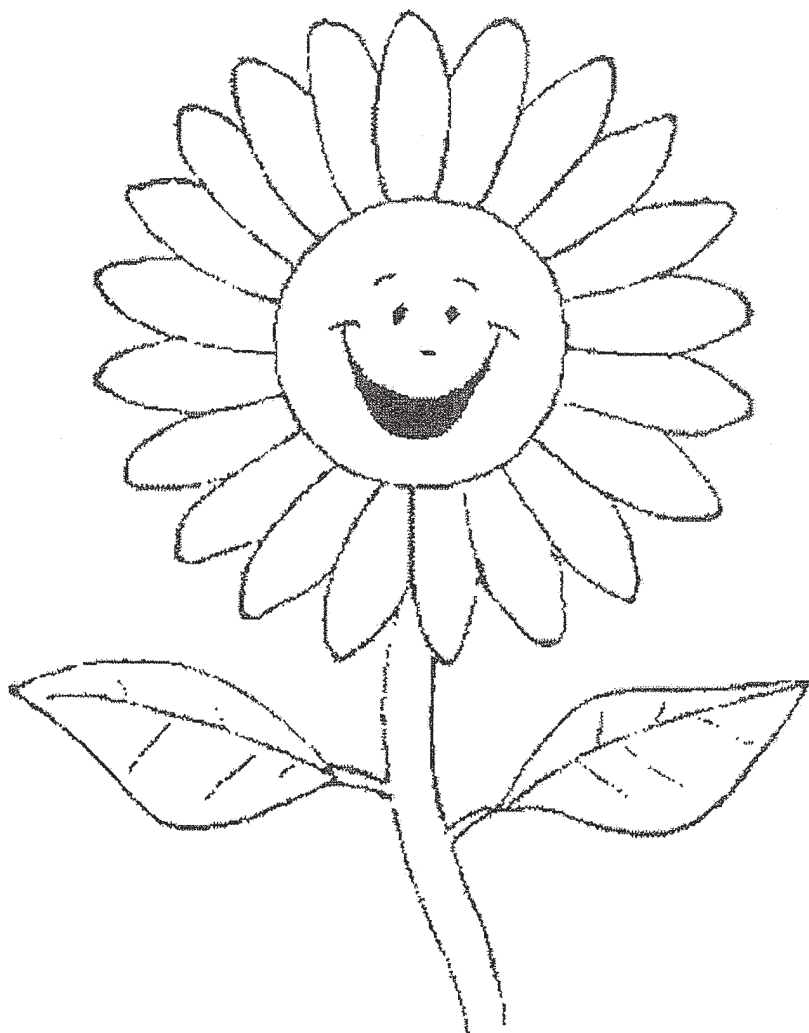

# tanulást!

# Papírhajtogatás

## Ház

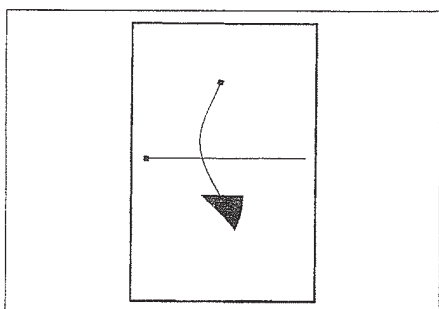

1. A felső részt  
lehajtjuk (A4)

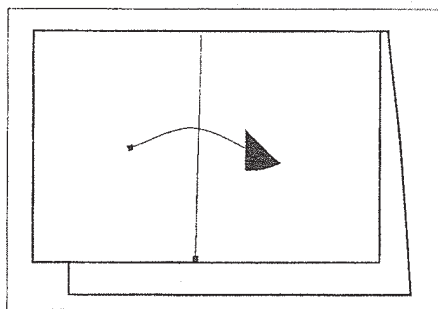

2. A bal oldalt  
jobbra hajtjuk

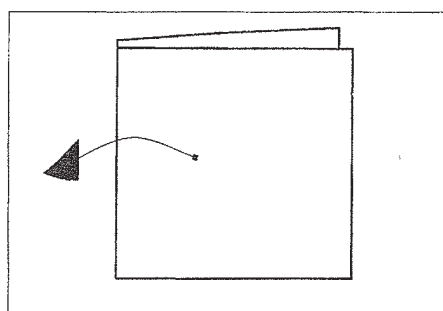

3. Visszahajtjuk

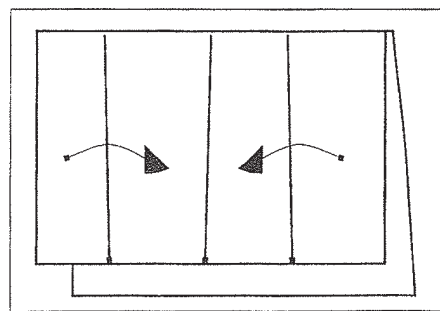

4. Az oldalakat  
középre hajtjuk

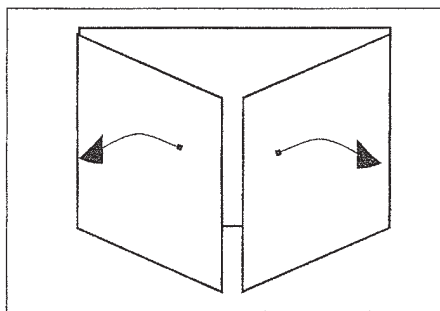

5. Visszahajtjuk

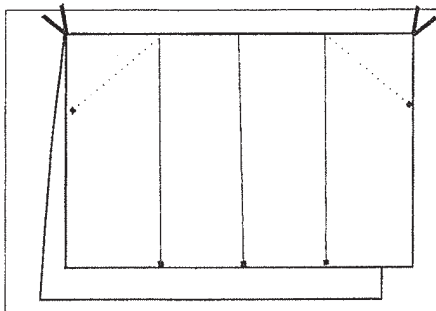

6. A sarkokat  
begyűrjük

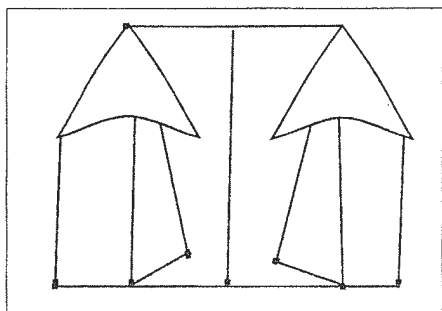

7. Lelapítjuk

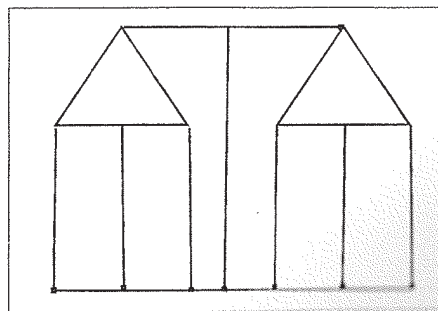

8. Kész a házikó

# Másold le az alakzatokat!

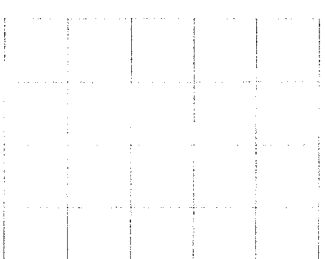
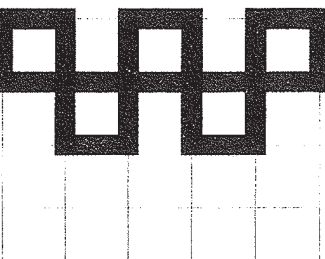
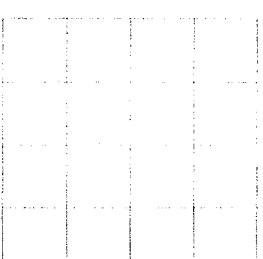
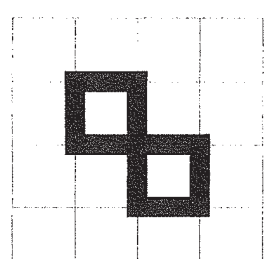
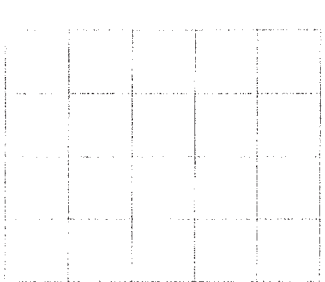
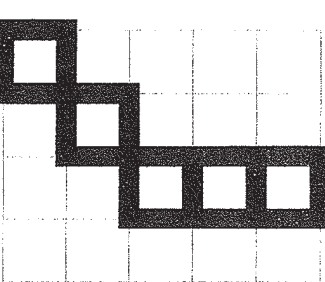
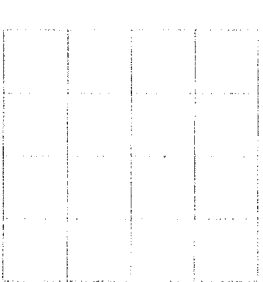
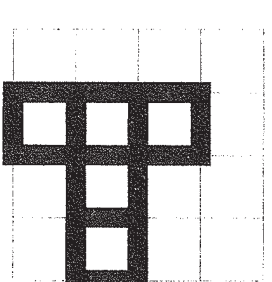
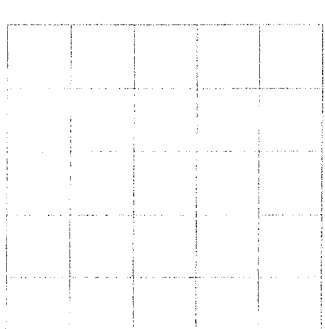
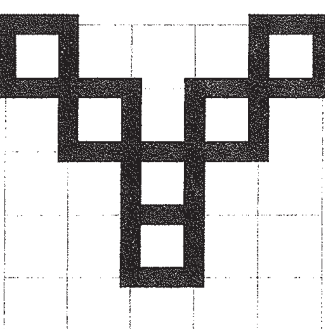
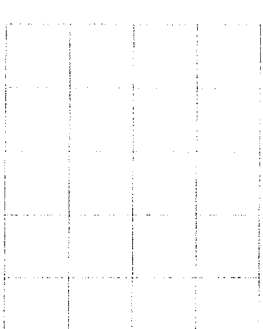
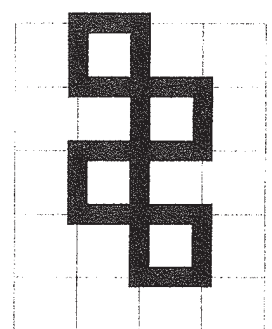
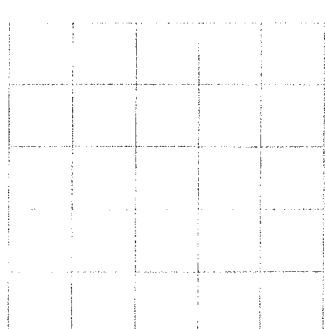
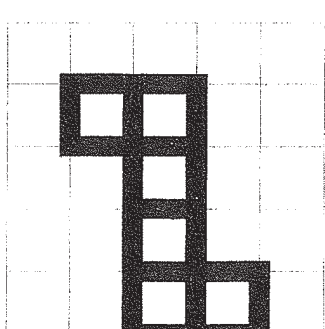
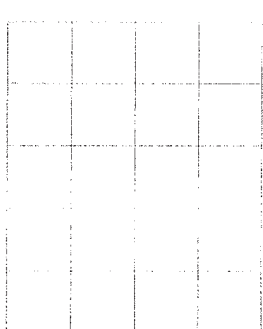
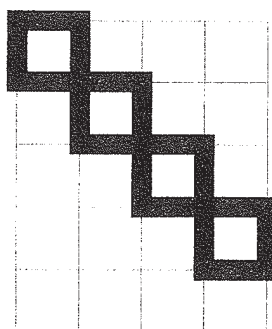
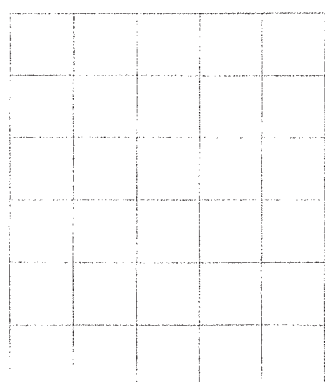
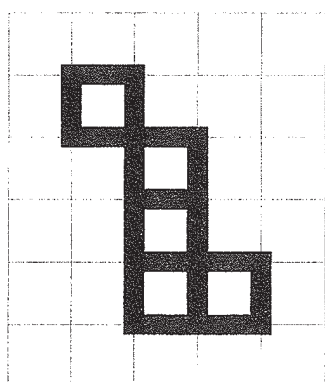
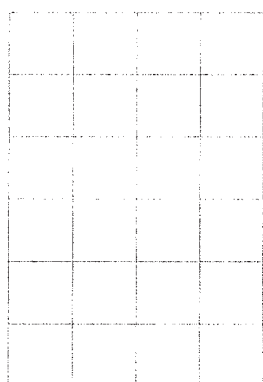
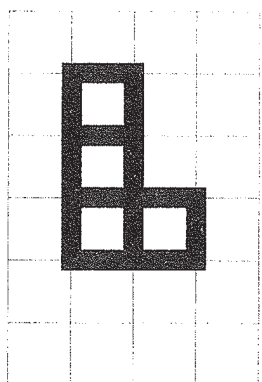

# A pont

1. a) Rajzolj a pont köré négyzetet, kösd össze a pontokat! Vonalzóval dolgozz!

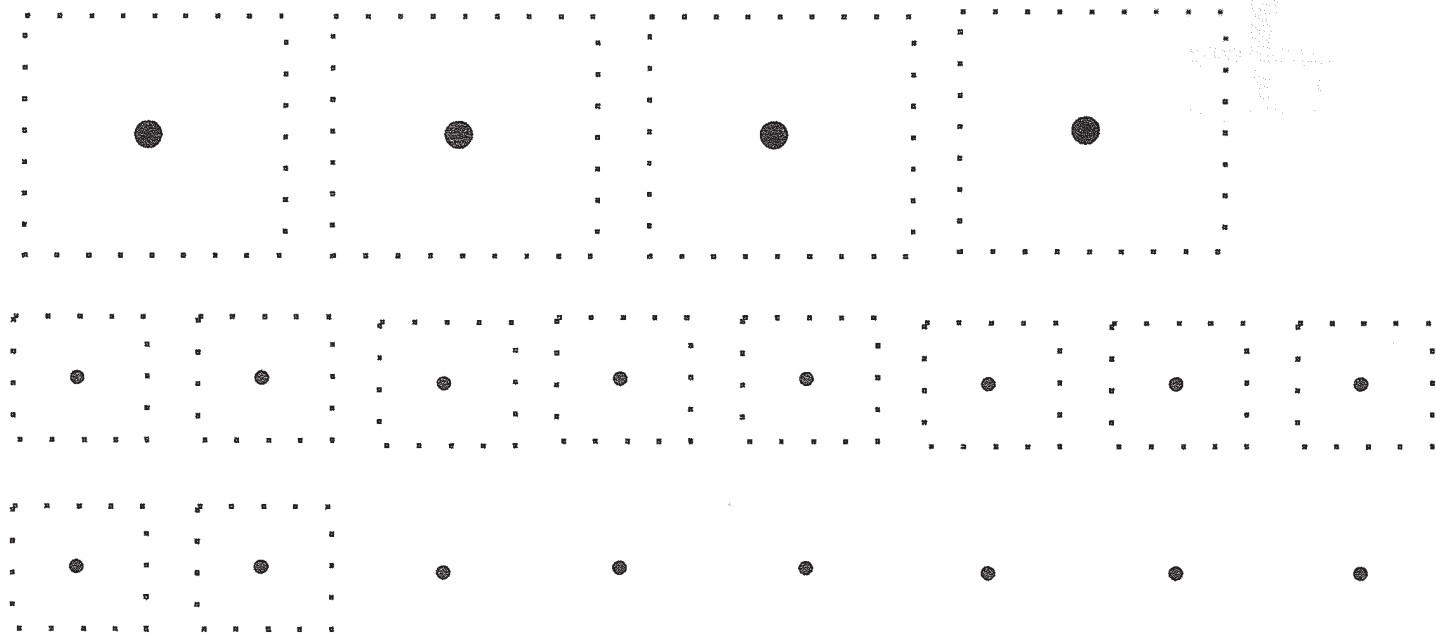

- b) Rajzolj a pont köré kört!

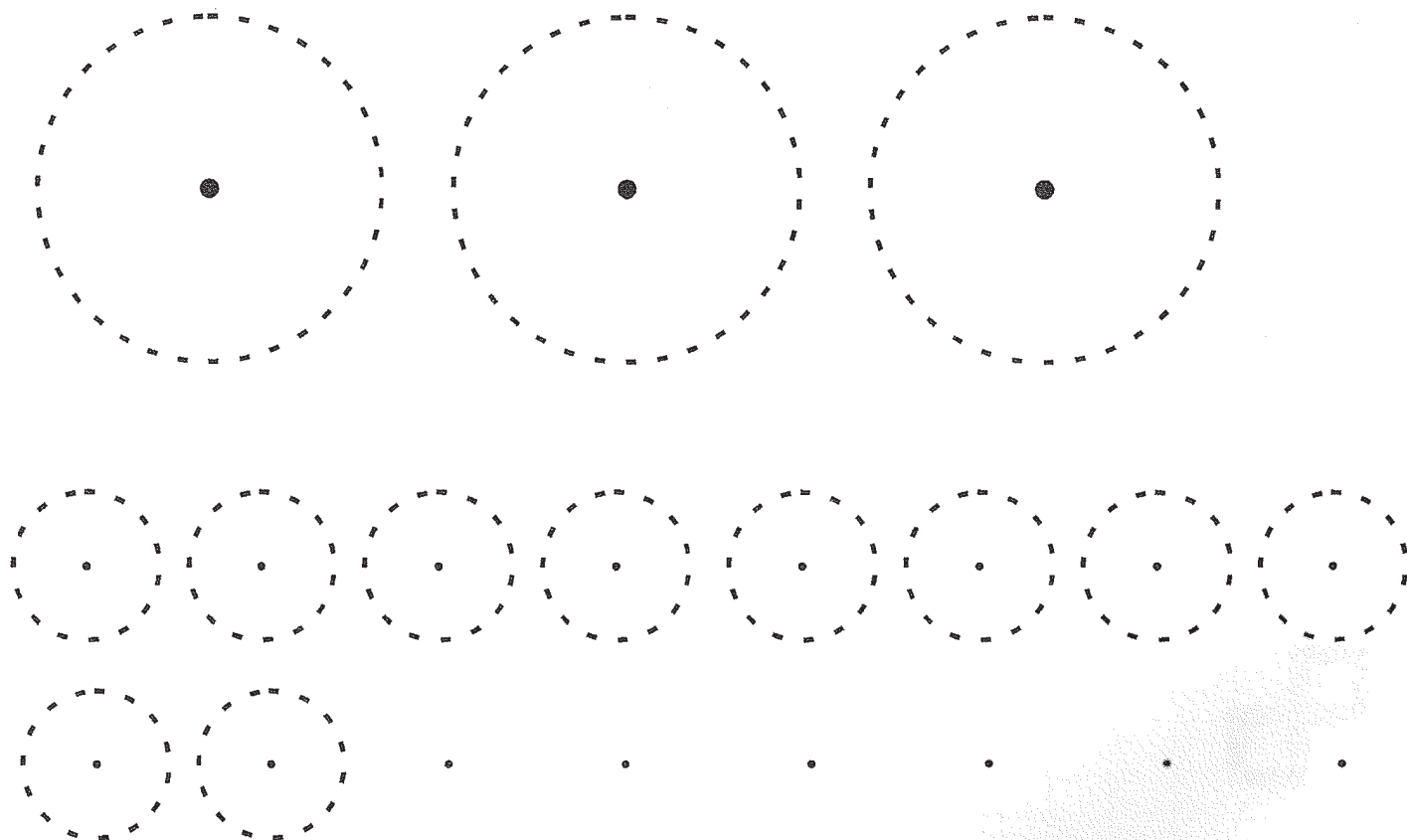



c) Köss össze pontokat vonalzó segítségével úgy, hogy különböző mértani alakzatokat kapj!

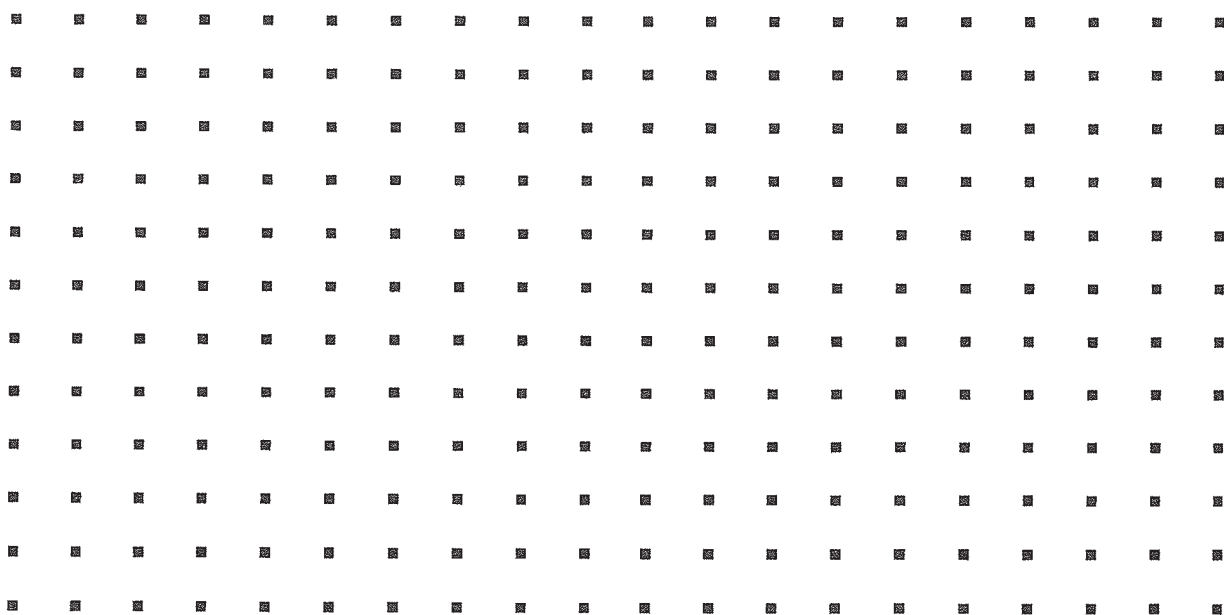

d) Jelöld a vonalak metszéspontját piros színessel!

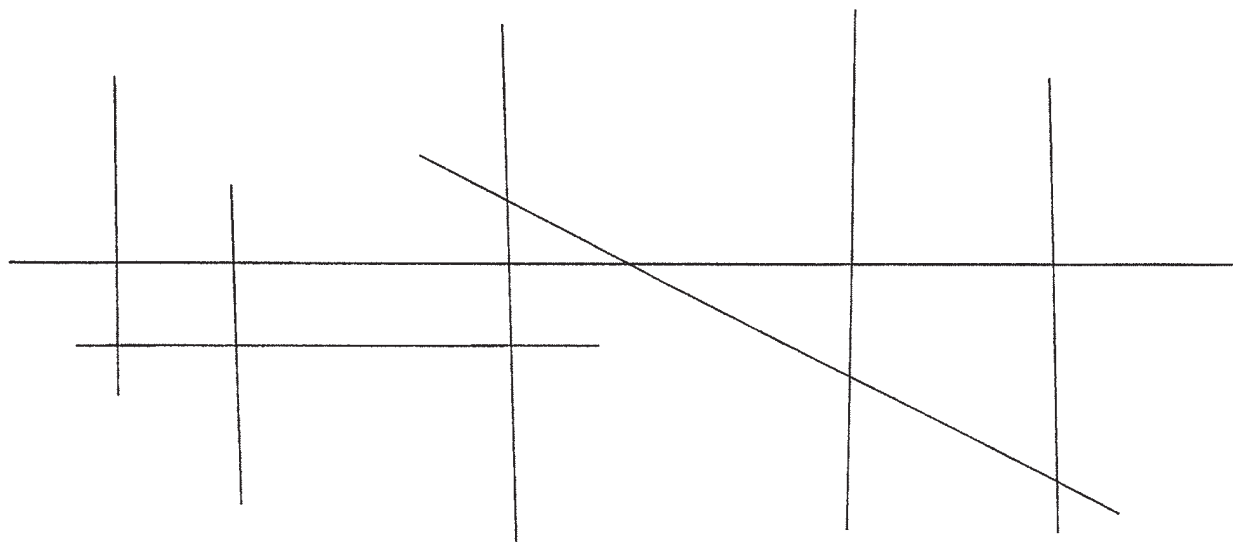
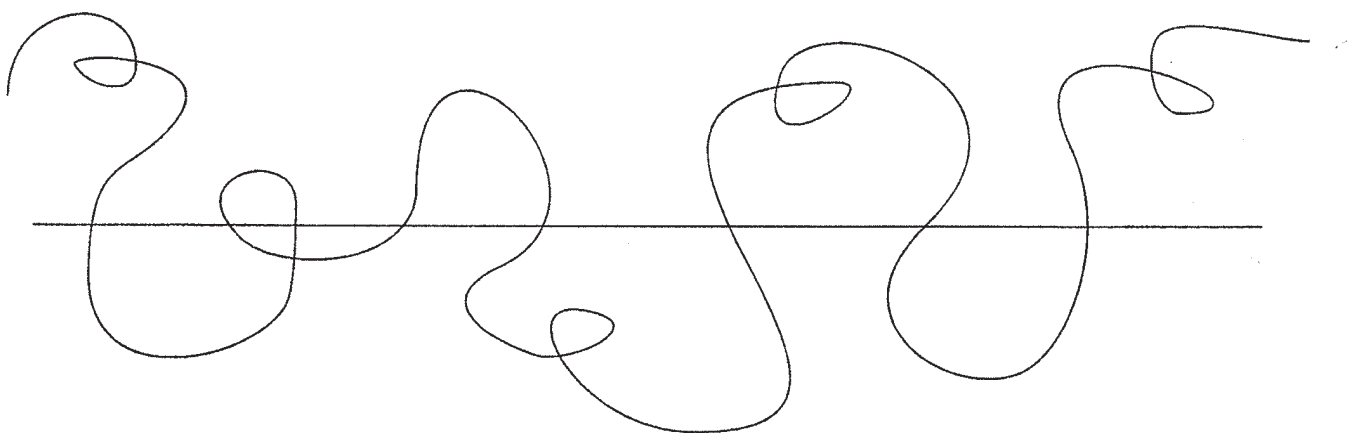

e) Pontok összekötése egyenes vonalakkal!

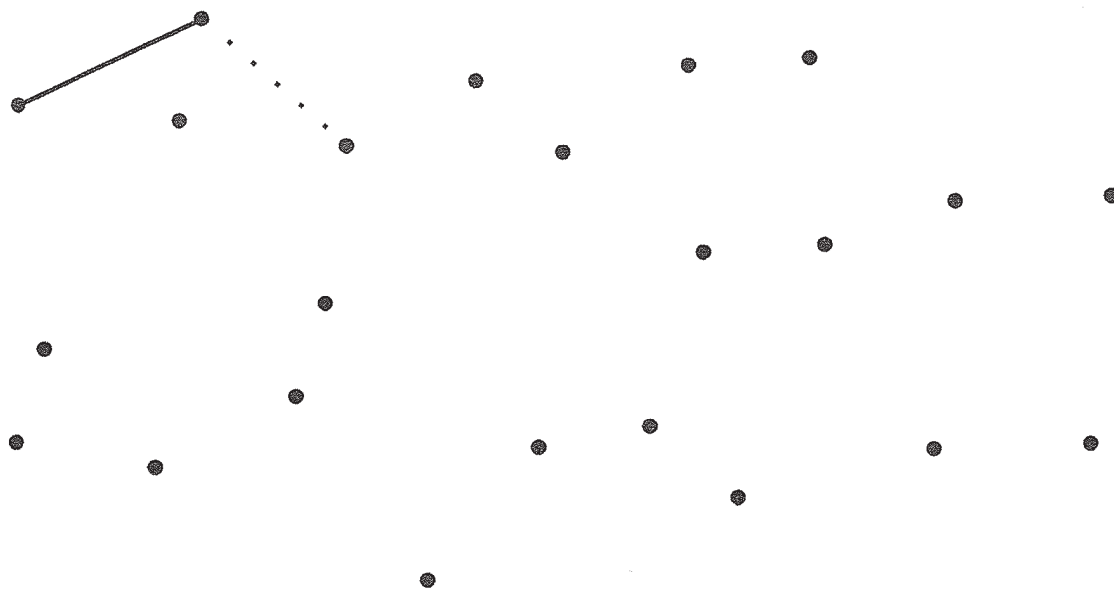

f) Pontok összekötése görbe vonalakkal!

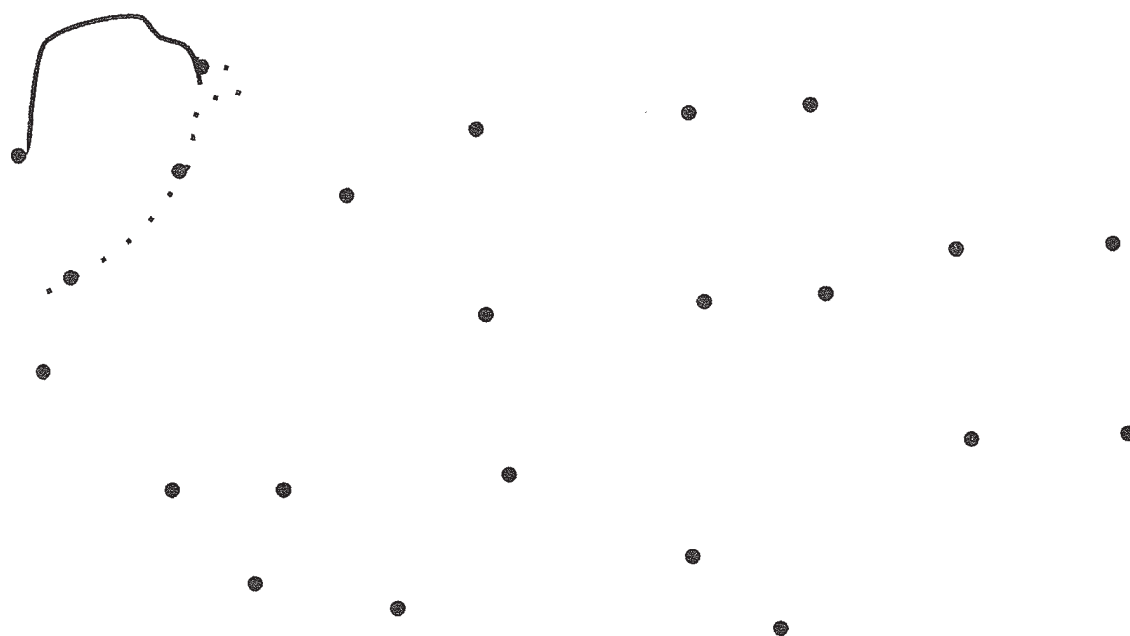

# A pont, mint két vonal metszete

1. a) Rajzolj vonalzóval vonalakat a pontokra!

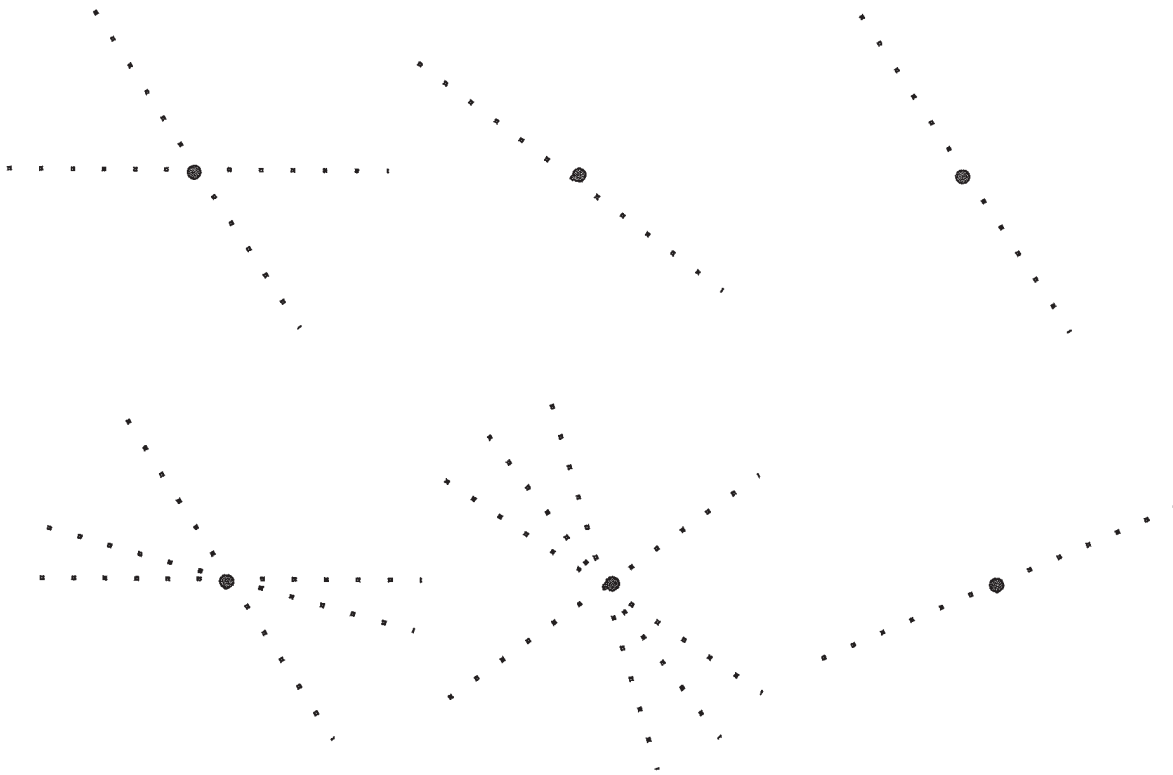

Egy ponton át hány egyenes húzható?  
Válasz: .....

b) Köss össze pontokat úgy, hogy háromszöget alkossanak!

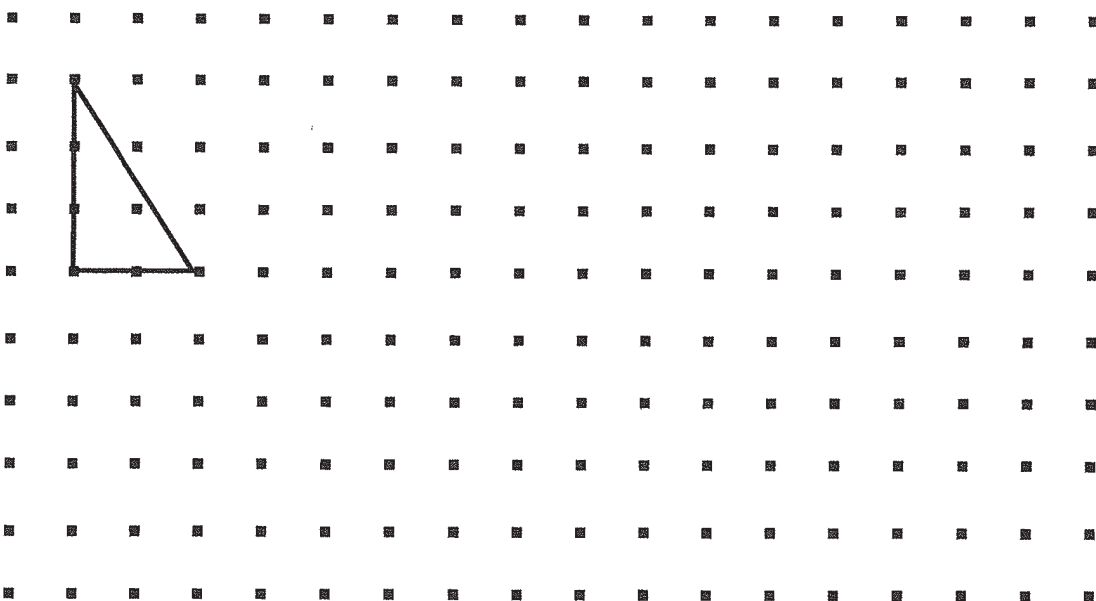



## Játék kockával

Hányat guríthatsz, hogy a holdtól a csillagig eljuss?

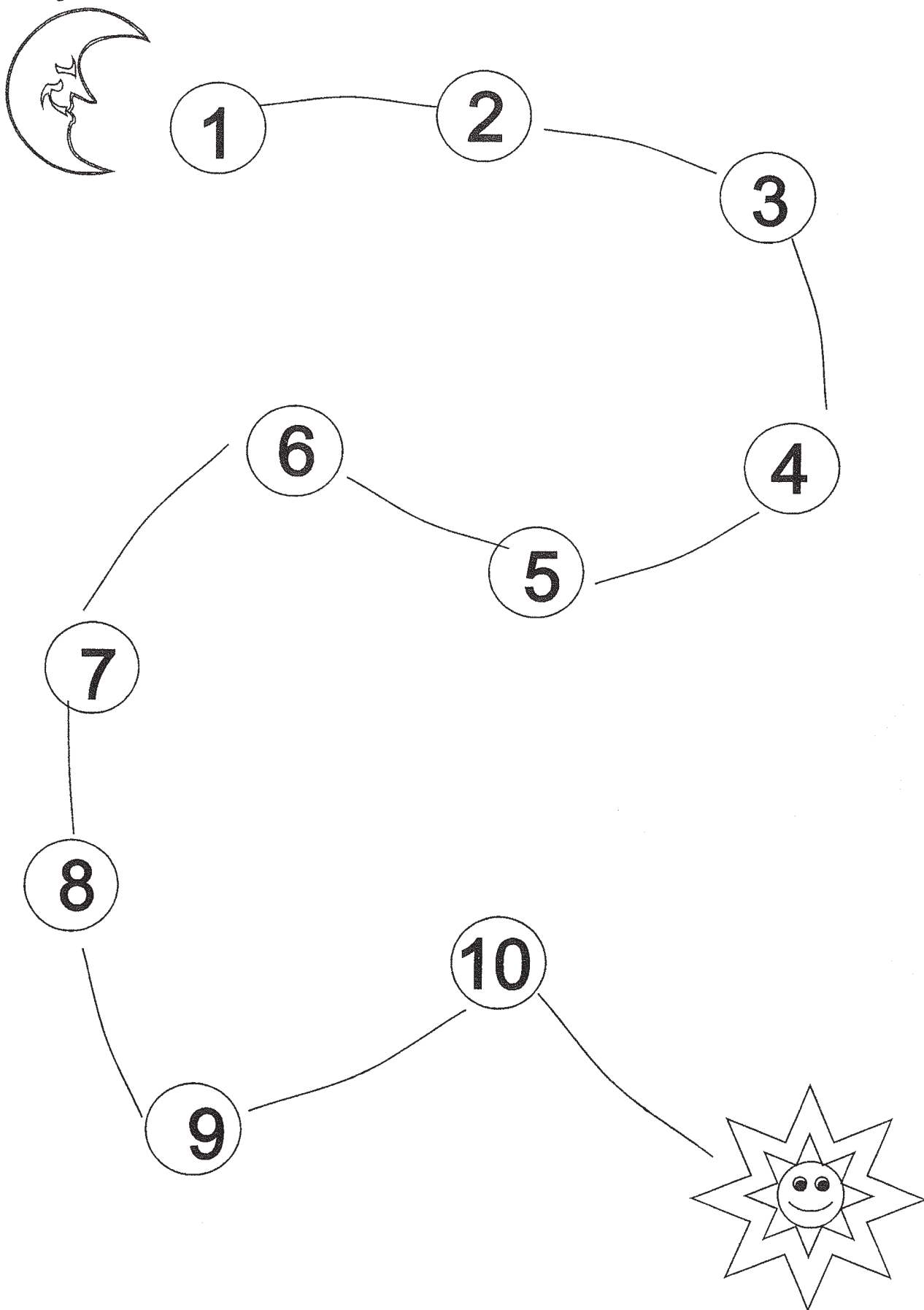



## Összeadás és kivonás szóban

1. Tapsolj egyet hangosan, hármat pedig halkán!  
Összesen hányat tapsoltál?
2. Tapsolj kettőt hangosan, egyet pedig halkán!  
Összesen hányat tapsoltál?
3. Kopogj a ceruzáddal négyet a füzetedre,  
azután az asztalra kettőt!  
Összesen hányat kopogtál?
4. Kopogj hármat az asztalra, a füzetedre semmit!  
Összesen hányat kopogtál?
5. Hófehérke két kosárba gombát szedett.  
Egyikbe 6-ot, másikba 4-et tett.  
Hány gombát szedett összesen?
6. Anya tíz fánkot tett a tálcára. Peti hármat megevett. Mennyi fánk maradt a tálcán?
7. Most 9 alma van a kosárban. Imre ötöt kivesz belőle. Mennyi maradt a kosárban?
8. A tortán nyolc gyertya ég. Sári nyolcat elfúj.  
Hány gyertya maradt égve?
9. Hány marad 10 eperből, ha 4-et megeszel?  
Hány marad 10 eperből, ha 8-at megeszel?  
Hány marad 6 eperből, ha 3-at megeszel?  
Hány marad 9 eperből, ha 5-öt megeszel?
10. Hánnyal kevesebb a 8 a 9-től?  
Hánnyal több a 4 a 2-től?  
Hánnyal kevesebb a 9 a 10-től?  
Hánnyal több az 5 az 1-től?

1. Kösd össze a számokat 1-től 10-ig!  
Színezd ki a rajzot! Rajzolj felhőt, alá napot,  
és a vízbe 10 halat!

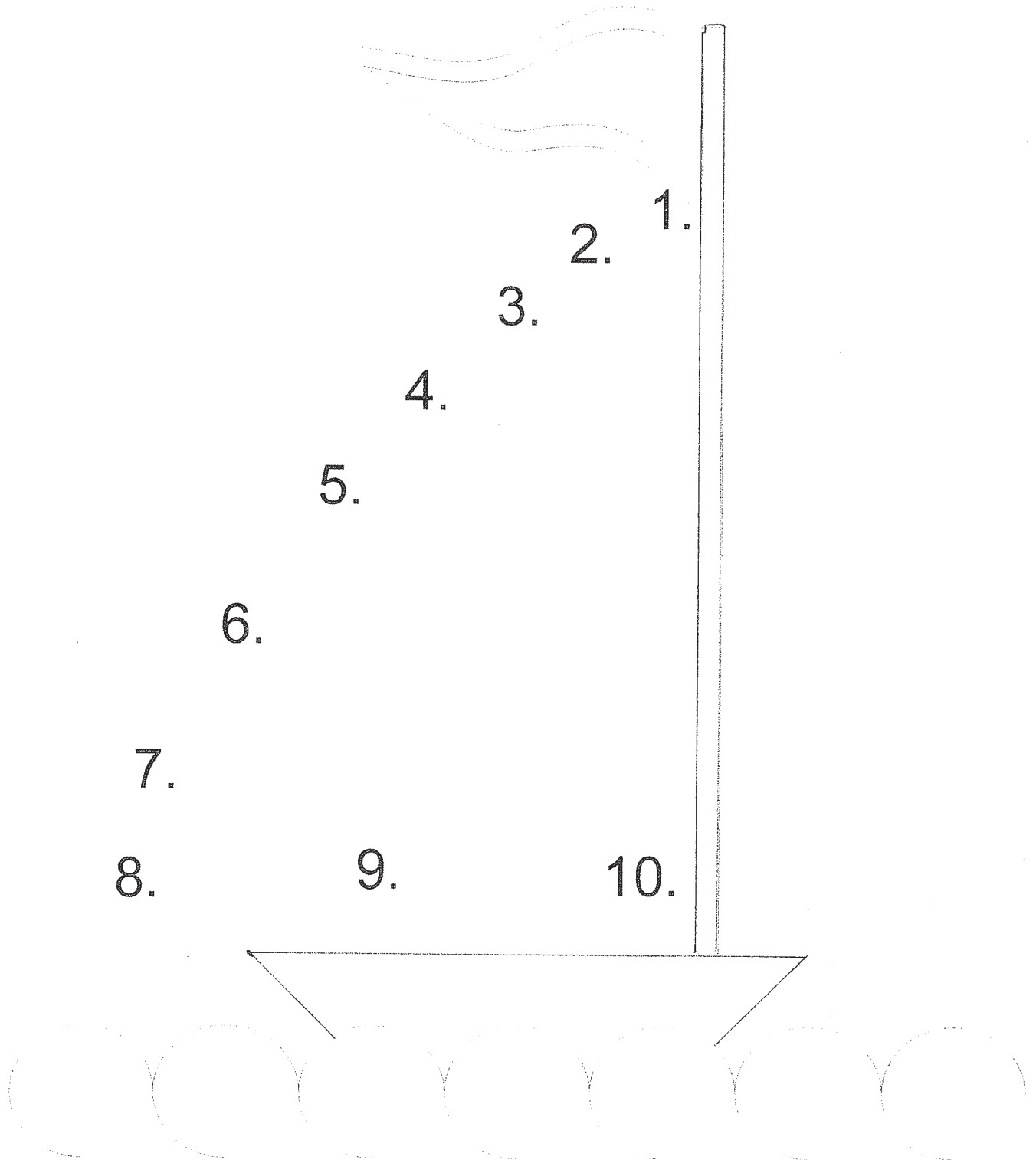



1. a)

**Rajzolj!**

**2 tányért**

**8 poharat**

**4 autót**

**9 ceruzát**

**7 madarat**

**5 kanalat**

**1 kerékpárt**

**3 nyuszt**

**6 csibét**

**10 fát**

b.)

Az előbbi feladatban:

- hány élőlény szerepel?.....
- hány élettelen dolog van?.....
- az élettelen dolgok közül .....  
hányat tudsz használni?.....
- az élőlények közül hány repül?.....
- hány kel ki a tojásból?.....

### 1. Számold meg a korongokat!

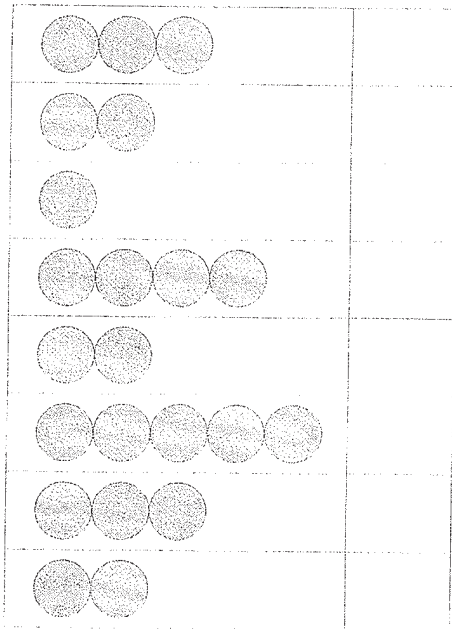
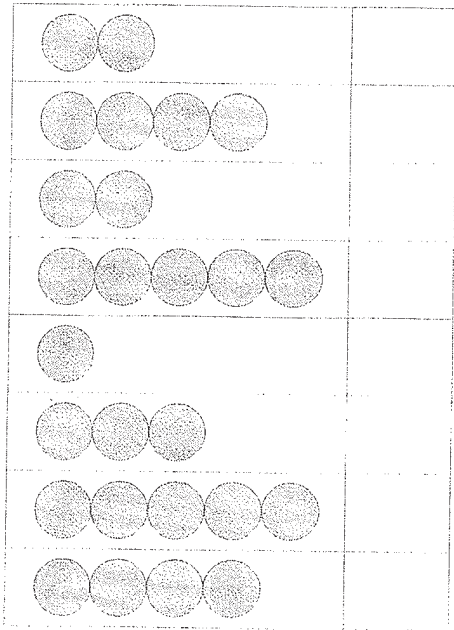

### 2. Rajzolj annyi piros labdát, amennyit a számok mutatnak!

	1
	3
	4
	7
	6

	0
	9
	2
	5
	8

# Összeadás és kivonás: 0, 1, 2



1. Írd fel műveletként!

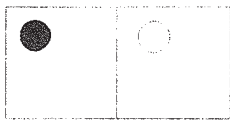

$$1 + \quad = \quad$$

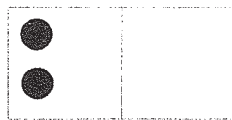

$$\quad + \quad = \quad$$



$$2 - \quad = \quad$$



$$1 + \quad = \quad$$

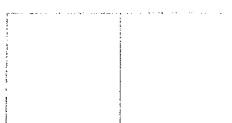

$$0 + \quad = \quad$$



$$2 - \quad = \quad$$

2. Számítsd ki!

$0+0=$	$0+ \cdot =0$	$\cdot +2=2$
$1+0=$	$1+ \cdot =1$	$\cdot +1=2$
$0+1=$	$0+ \cdot =1$	$\cdot +0=2$
$1+1=$	$1+ \cdot =2$	$0+ \cdot =2$

3. $1-0=$	$1- \cdot =1$	$\cdot -1=1$
$1-1=$	$1- \cdot =0$	$\cdot -0=2$
$2-1=$	$2- \cdot =2$	$\cdot -0=0$
$2-0=$	$2- \cdot =1$	$\cdot -2=2$

0	1	2																	
0	1	2																	

# Összeadás és kivonás: 3



1. Írd fel műveletként!

$\square + \square = \square$	$\square + \square = \square$	$\square + \square = \square$
$\square - \square = \square$	$\square - \square = \square$	$\square - \square = \square$

2. Számítsd ki!

$1+1=$	$0+2=$	$0+2=$
$3+0=$	$0+3=$	$1+2=$
$2+1=$	$2+2=$	$0+1=$

$2 + \cdot = 3$	$\cdot + 1 = 3$	$\cdot + 3 = 3$
$3 + \cdot = 3$	$\cdot + 2 = 3$	$0 + \cdot = 3$
$3 - 1 =$	$3 - 0 =$	$3 - 3 =$
$3 - 2 =$	$0 - 2 =$	$2 - 1 =$

3. Írd be a <, >, = jelet!

$2+1 \square 3-0$	$1+1 \square 3-2$
$2-1 \square 0+3$	$3-2 \square 3+1$

0	1	2	3																
0	1	2	3																

# Összeadás és kivonás: 4



1. Írd fel műveletként!

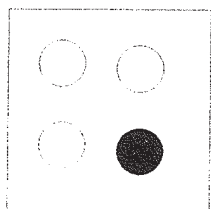

$\square + \square = \square$

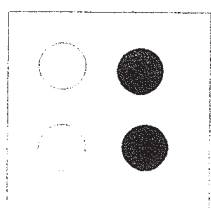

$\square + \square = \square$

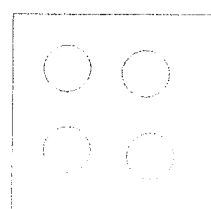

$\square + \square = \square$

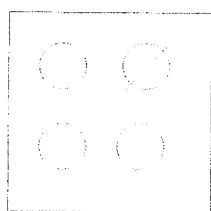

$\square - \square = \square$

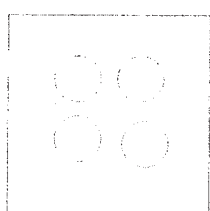

$\square - \square = \square$

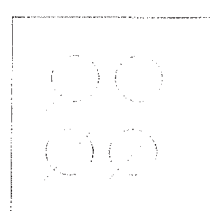

$\square - \square = \square$

2. Számítsd ki!

$2+1=$        $1+2=$        $0+4=$   
 $3+1=$        $1+3=$        $4+0=$   
 $1+1=$        $2+2=$        $0+1=$

$4 + \square = 4$        $\square + 1 = 4$        $\square + 4 = 4$   
 $3 + \square = 4$        $\square + 2 = 4$        $0 + \square = 4$

$4-1=$        $4-0=$        $4-3=$   
 $4-2=$        $0-4=$        $4-4=$

3. Írd be <, >, = jelet!

$3+1 \square 4-0$        $1+1 \square 3-2$        $3-1 \square 4-2$   
 $2-1 \square 1+3$        $4-2 \square 3+1$        $2+2 \square 4-0$

0	1	2	3	4															
0	1	2	3	4															

## Összeadás és kivonás: 5



1. Végy a kezébe 5 ceruzát! Tégy az asztalra kettőt. Hány maradt a kezében?  
Írd fel műveletként! .....

2. A jobb kezében legyen 1 ceruza, a balban pedig 4! Összesen hány ceruza van a két kezében?  
Írd fel műveletként! .....

3. Számítsd ki!

$1+4=$        $2+2=$        $3+ \cdot =5$

$4+1=$        $3+1=$        $2+ \cdot =5$

$3+2=$        $1+1=$        $1+ \cdot =5$

$2+3=$        $5+0=$        $0+ \cdot =5$

$5-1=$        $2-1=$        $5-5=$        $5- \cdot =3$

$5-2=$        $2-2=$        $5-3=$        $5- \cdot =2$

$5-0=$        $3-2=$        $4-1=$        $5- \cdot =1$

$5-4=$        $4-4=$        $5-3=$        $5- \cdot =4$

4. Írd be  $<$ ,  $>$ ,  $=$  jelet!

$1+3 \square 2-1$        $4+0 \square 3-1$

$4+1 \square 1+3$        $5-0 \square 2+3$

$2+0 \square 5-3$        $3+2 \square 0+5$

$5-2 \square 1+2$        $4-1 \square 1+0$

## Összeadás és kivonás: 6



1. Pótold a dominókon a pontokat úgy, hogy 6 legyen mindegyiken!

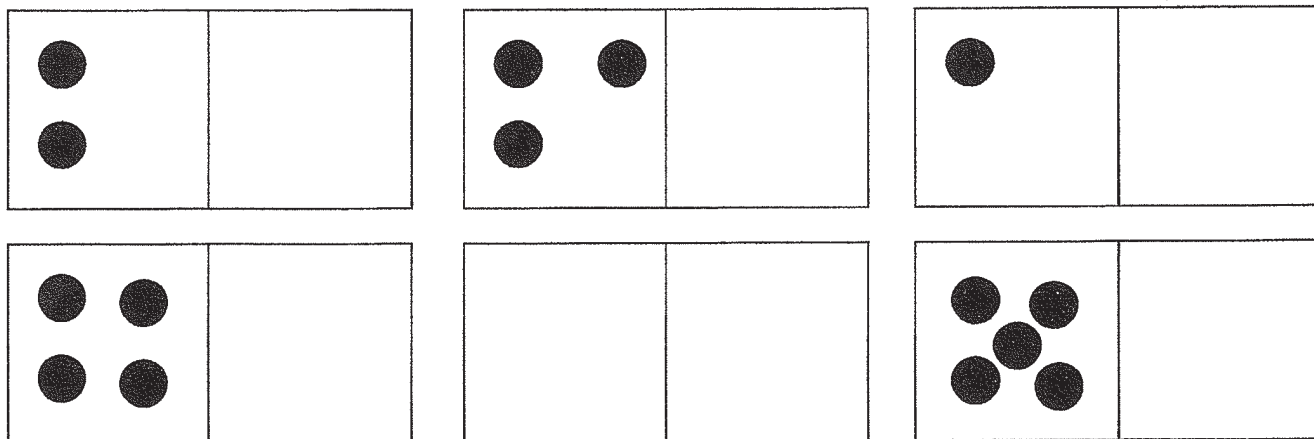

2. Bontsd a hatost két részre!

Dolgozz korongok segítségével!

6		6	
6	6 + . = .	4	. + 4 = .
5	5 + . = .	3	. + 3 = .
4	4 + . = .	2	. + 2 = .
3	3 + . = .	5	. + 5 = .
2	2 + . = .	6	. + 6 = .
1	1 + . = .	0	. + 0 = .
0	0 + . = .	1	. + 1 = .

3. Számítsd ki!

5+1=	2+4=	2+3=	6-3=	6-1=
4+2=	3+1=	4+1=	6-5=	6-6=
3+3=	0+6=	1+3=	6-4=	6-2=
1+5=	2+0=	3+2=	6-0=	

## Összeadás és kivonás: 7



1. Hányat kell lépned:

- ... a hatosról a hetesre? \_\_\_\_\_
- ... és a négyesről a hetesre? \_\_\_\_\_
- ... és a kettesről a hetesre? \_\_\_\_\_
- ... és az ötösről a hetesre? \_\_\_\_\_

2. Bontsd a hetet két számra!

$\cdot + \cdot = 7$	$\cdot + \cdot = 7$	$\cdot + \cdot = 7$	$\cdot + \cdot = 7$
$\cdot + \cdot = 7$	$\cdot + \cdot = 7$	$\cdot + \cdot = 7$	$\cdot + \cdot = 7$

3. Számítsd ki!

a) $2+5=$	$3+4=$	$7+0=$	$1+2+3=$
$3+1=$	$4+2=$	$1+5=$	$2+4+1=$
$4+3=$	$5+2=$	$5+1=$	$3+1+2=$
$4+4=$	$2+5=$	$0+7=$	$1+2+4=$
$1+6=$	$6+1=$	$3+3=$	$2+0+5=$

b) $7-1=$	$7-4=$	$7-7=$
$7-5=$	$7-0=$	$7-2=$
$7-6=$	$7-3=$	$0-7=$

7	7																		
5	6	7																	
1	2	3	4	5	6	7													



## Összeadás és kivonás: 8



1. a) Tegyéél az asztalra hét ceruzát!  
Mit kell tenned, hogy nyolc legyen?
  - b) A nyolc ceruzából hármát vegyéél el!  
Hány maradt az asztalon?
2. a) Bontsd fel a nyolcat két részre!

8	8
8	4
7	6
6	3
5	8
4	5
3	0
2	1
1	7

b) Pótold a számokat!

$4 + \cdot = 8$	$0 + \cdot = 8$
$3 + \cdot = 8$	$2 + \cdot = 8$
$6 + \cdot = 8$	$7 + \cdot = 8$
$1 + \cdot = 8$	$5 + \cdot = 8$

3. Számítsd ki!

$8 - 2 =$	$8 - 8 =$	$5 + 3 =$	$1 + 6 =$
$8 - 3 =$	$8 - 7 =$	$2 + 6 =$	$2 + 5 =$
$8 - 6 =$	$8 - 1 =$	$4 + 4 =$	$3 + 5 =$
$8 - 4 =$	$8 - 5 =$	$0 + 8 =$	$8 + 0 =$

## Összeadás és kivonás: 9



1. Hányat kell lépni a nyolcastól a kilencesig,  
... a hatostól a kilencesig, \_\_\_\_\_  
... a hetestől a kilencesig? \_\_\_\_\_

2. Pótold a hiányzó számokat!

3		5		1			4	5		2
0	1			5		2		4		6
4			7		9	2				

3. Hasonlítsd össze a számokat!

Írd be a <, >, = jelet!

3 <input type="text"/> 6	2 <input type="text"/> 7	6 <input type="text"/> 7	9 <input type="text"/> 9	7 <input type="text"/> 6
4 <input type="text"/> 7	3 <input type="text"/> 8	3 <input type="text"/> 9	6 <input type="text"/> 5	4 <input type="text"/> 4
9 <input type="text"/> 8	6 <input type="text"/> 9	7 <input type="text"/> 3	5 <input type="text"/> 2	8 <input type="text"/> 9

4. Az összeg legyen 9!

6 + <input type="text"/>	2 + <input type="text"/>	8 + <input type="text"/>	4 + <input type="text"/>	5 + <input type="text"/>
1 + <input type="text"/>	<input type="text"/> + 9	<input type="text"/> + 5	<input type="text"/> + 0	7 + <input type="text"/>

5. Számítsd ki!

9-8=	9-1=	5+4=	8+1=
9-7=	9-3=	6+3=	4+5=
9-5=	9-9=	2+7=	3+6=
9-0=	9-2=	9+0=	1+8=

## Összeadás és kivonás: 10

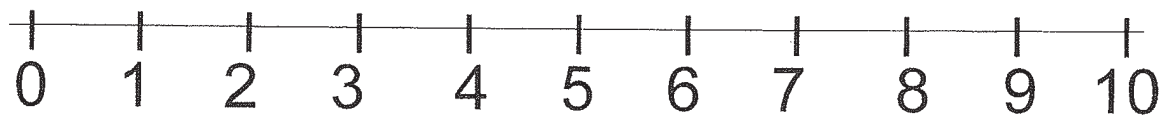

1. Számold meg az ujjaidat mindkét kezeden!  
Először egytől tízig, azután pedig visszafelé!

2. a) Papírból vágj ki tíz négyzetet!  
Építs belőle házat! Hány emeletes lett?

b) A kivágott négyzetekből építs két emeletes házat! Hány négyzetből állhatnak?  
Írd le összegként is!

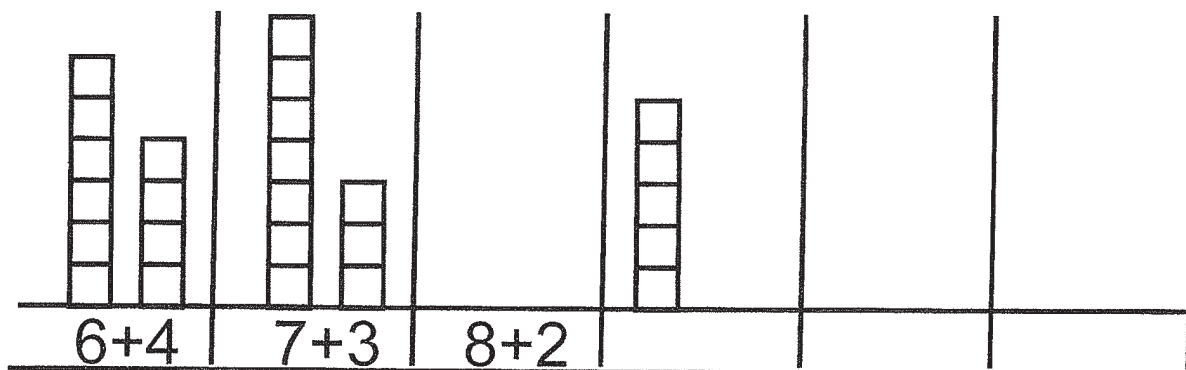

3. A kosárban 8 alma van, a ládában pedig 9.  
Hol van több alma? \_\_\_\_\_

4. A tanteremben 10 szék van. Ha egyet kivisznek  
a folyosóra, mennyi marad bent? \_\_\_\_\_

5. Mennyi; 2 tyúk, meg még 6 tyúk? \_\_\_\_\_  
8 ház, meg 2 ház? \_\_\_\_\_  
7 autó, meg 3 autó? \_\_\_\_\_

# Számok pótlása 5-ig

1.

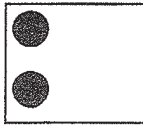

$2 + \square = 5$

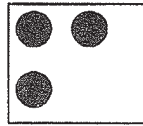

$3 + \square = 5$

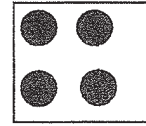

$4 + \square = 5$

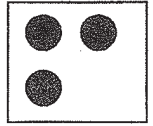

$3 + \square = 4$

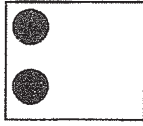

$2 + \square = 4$

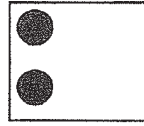

$2 + \square = 3$

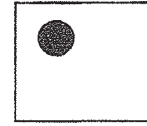

$1 + \square = 4$

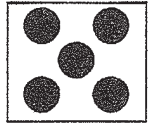

$5 + \square = 5$

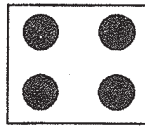

$\square + \square = 5$

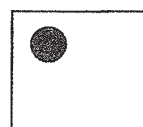

$1 + \square = 5$



$0 + \square = 4$

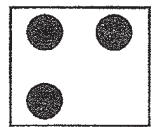

$3 + \square = 3$

2. Pótold a hiányzó számot!

$1 + \square = 3$

$2 + \square = 5$

$3 + \square = 4$

$1 + \square = 5$

$2 + \square = 3$

$3 + \square = 3$

$4 + \square = 4$

$1 + \square = 4$

$2 + \square = 4$

$3 + \square = 5$

$5 + \square = 5$

$1 + \square = 2$

$2 + \square = 2$

$4 + \square = 5$

3. Mennyit kell hozzáadni:

... kettőhöz, hogy három legyen? \_\_\_\_\_

... négyhez, hogy öt legyen? \_\_\_\_\_

... nullához, hogy öt legyen? \_\_\_\_\_

... háromhoz, hogy négy legyen? \_\_\_\_\_

... öthöz, hogy öt legyen? \_\_\_\_\_

... háromhoz, hogy négy legyen? \_\_\_\_\_

... kettőhöz, hogy öt legyen? \_\_\_\_\_

# Pótlás a 10-es számkörben

1. Pótolj a pontokat, hogy 10 legyen!

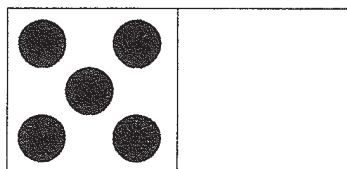
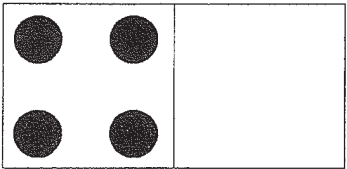
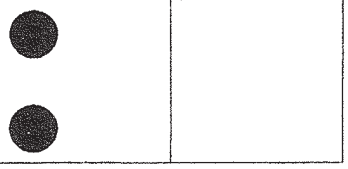
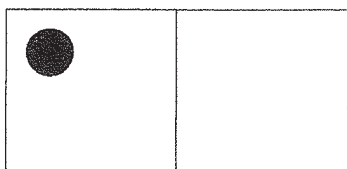
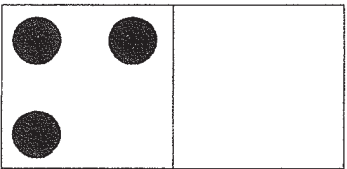
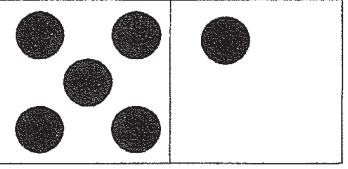
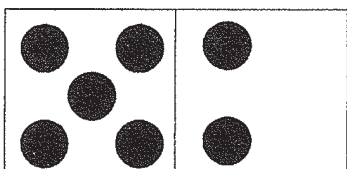
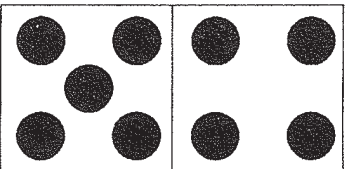
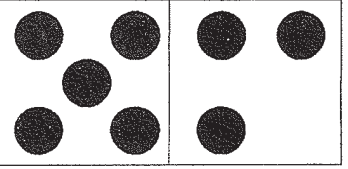
		
5 + <input type="text"/> = 10	<input type="text"/> + <input type="text"/> = 10	<input type="text"/> + <input type="text"/> = 10
		
<input type="text"/> + <input type="text"/> = 10	<input type="text"/> + <input type="text"/> = 10	<input type="text"/> + <input type="text"/> = 10
		
<input type="text"/> + <input type="text"/> = 10	<input type="text"/> + <input type="text"/> = 10	<input type="text"/> + <input type="text"/> = 10

2. Végezd el a következő pótlásokat!

$10$	$10$	$10$	$10$
$3 + \square$	$5 + \square$	$7 + \square$	$6 + \square$
$10$	$10$	$10$	$10$
$8 + \square$	$9 + \square$	$4 + \square$	$2 + \square$

3. Hányat kell hozzáadni:

- .. a 9-hez, hogy 10 legyen, \_\_\_\_\_
- ... a 4-hez, hogy 10 legyen, \_\_\_\_\_
- ... a 7-hez, hogy 10 legyen, \_\_\_\_\_
- ... a 8-hoz, hogy 10 legyen? \_\_\_\_\_

# Összeadás és kivonás: 10

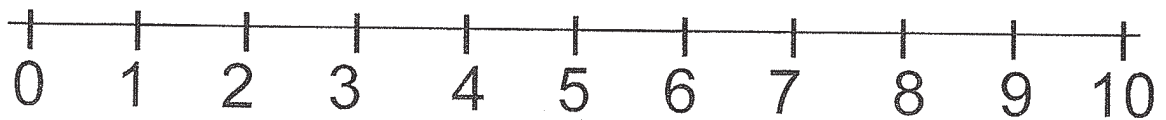

1. a) Bontsd fel a tízet két részre!

10	10
10	4
9	6
8	3
7	8
6	5
5	0
4	1
3	7
2	9
1	10

b) Pótold a számokat!

$$4 + \dots = 10$$

$$0 + \dots = 10$$

$$3 + \dots = 10$$

$$2 + \dots = 10$$

$$6 + \dots = 10$$

$$7 + \dots = 10$$

$$1 + \dots = 10$$

$$5 + \dots = 10$$

3. Számítsd ki!

$10 - 2 =$

$10 - 8 =$

$7 + 3 =$

$3 + 6 =$

$10 - 3 =$

$10 - 7 =$

$2 + 8 =$

$5 + 5 =$

$10 - 6 =$

$10 - 1 =$

$4 + 6 =$

$4 + 5 =$

$10 - 4 =$

$10 - 5 =$

$1 + 8 =$

$9 + 1 =$

4. Hány lába van:

- 2 libának, \_\_\_\_\_

- 4 tyúknak, \_\_\_\_\_







- 2 lónak, \_\_\_\_\_

- 1 lónak és 3 libának, \_\_\_\_\_

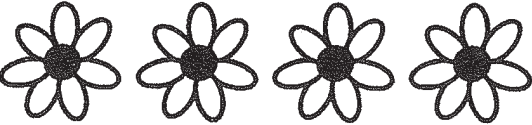
- 2 lónak és 1 tyúknak? \_\_\_\_\_

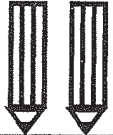
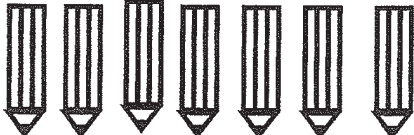
# Összeadandók helycseréje

1.

		$3+4=7$ $4+3=7$
		$4+6=$ <input type="text"/> $6+4=$ <input type="text"/>
		$2+7=$ <input type="text"/> $7+2=$ <input type="text"/>
		$3+ . =$ <input type="text"/> $. + . =$ <input type="text"/>
		$. + . =$ <input type="text"/> $. + . =$ <input type="text"/>

2. Írd fel összegként!

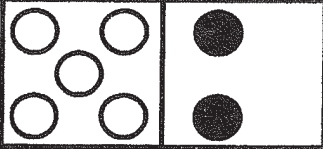
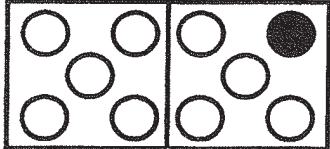
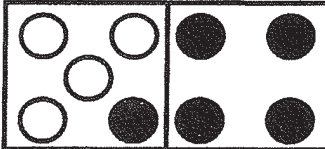
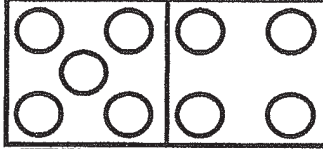
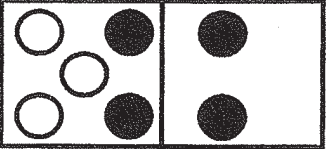
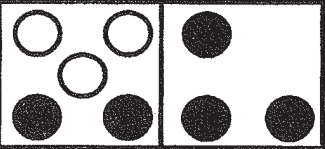
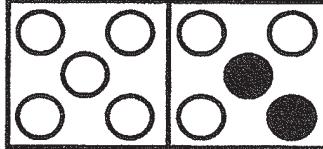
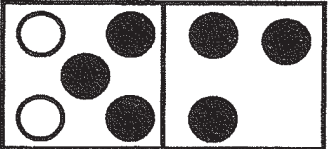
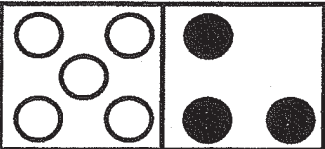
 $5 + 2 =$ <input type="text"/> $2 +$ <input type="text"/> $=$ <input type="text"/>	 $9 + 1 =$ <input type="text"/> $+$ <input type="text"/> $=$ <input type="text"/>	 $4 +$ <input type="text"/> $=$ <input type="text"/> $+$ <input type="text"/> $=$ <input type="text"/>
 $9 +$ <input type="text"/> $=$ <input type="text"/> $+$ <input type="text"/> $=$ <input type="text"/>	 $3 +$ <input type="text"/> $=$ <input type="text"/> $+$ <input type="text"/> $=$ <input type="text"/>	 $+ 5 =$ <input type="text"/> $+$ <input type="text"/> $=$ <input type="text"/>
 $8 +$ <input type="text"/> $=$ <input type="text"/> $+$ <input type="text"/> $=$ <input type="text"/>	 $2 +$ <input type="text"/> $=$ <input type="text"/> $+$ <input type="text"/> $=$ <input type="text"/>	 $+$ <input type="text"/> $=$ <input type="text"/> $+$ <input type="text"/> $=$ <input type="text"/>

# Összeadás szóban

1.			
2.			
3.			
4.			
5.			
6.			
7.			
8.			



# Kivonás szóban

1.			
2.			
3.			
4.			
5.			
6.			
7.			
8.			

## Feladatok a 10-es számkörben

1. Pótold a hiányzó számokat!

a) 1 \_ \_ 4 \_ \_ 7 \_ \_ \_

b) 

	6	
--	---	--

		1	0
--	--	---	---

		3	
--	--	---	--

		8	
--	--	---	--

		7	
--	--	---	--

		4	
--	--	---	--

--	--	--	--

--	--	--	--

5

9

2. Hány téglá van összesen a két sorban?  
Írd fel műveletként!



\_\_\_\_\_

3. A kacsának nincsen mása,  
volt neki tíz tojása. (Rajzold le a 10 tojást!)



Hiába volt tíz neki, mert csak hetet költött ki.  
(Rajzold le a 7 kacsát!)



Hány tojás maradt ép?  
Hogyan írnád le az előbbi mondókat  
matematikai műveletként?

Rajzold le a  
kacsamamát is!

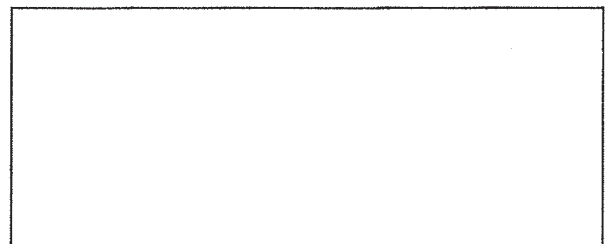

1. a) Készíts kartonból két tányért és tíz almát!

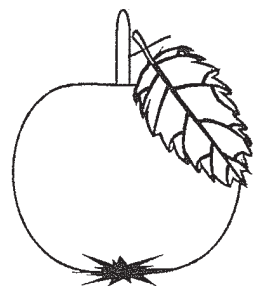
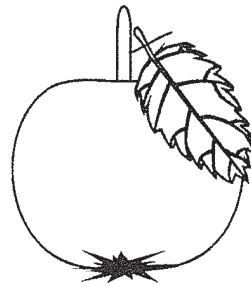
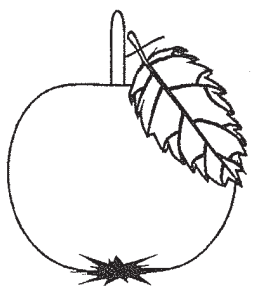
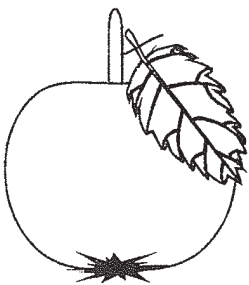
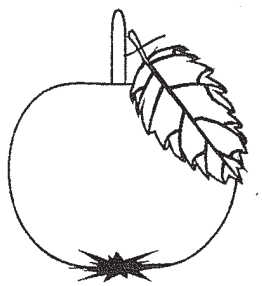
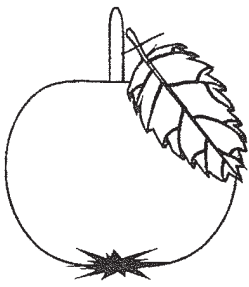
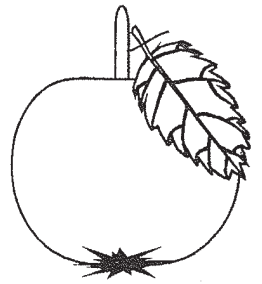
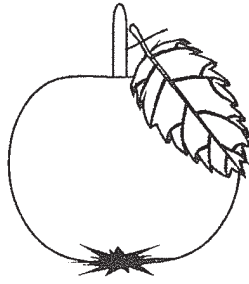
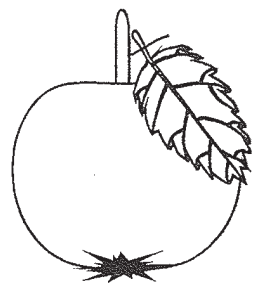
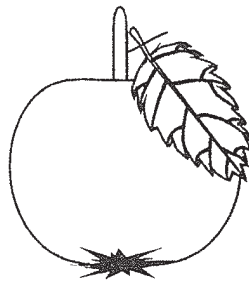
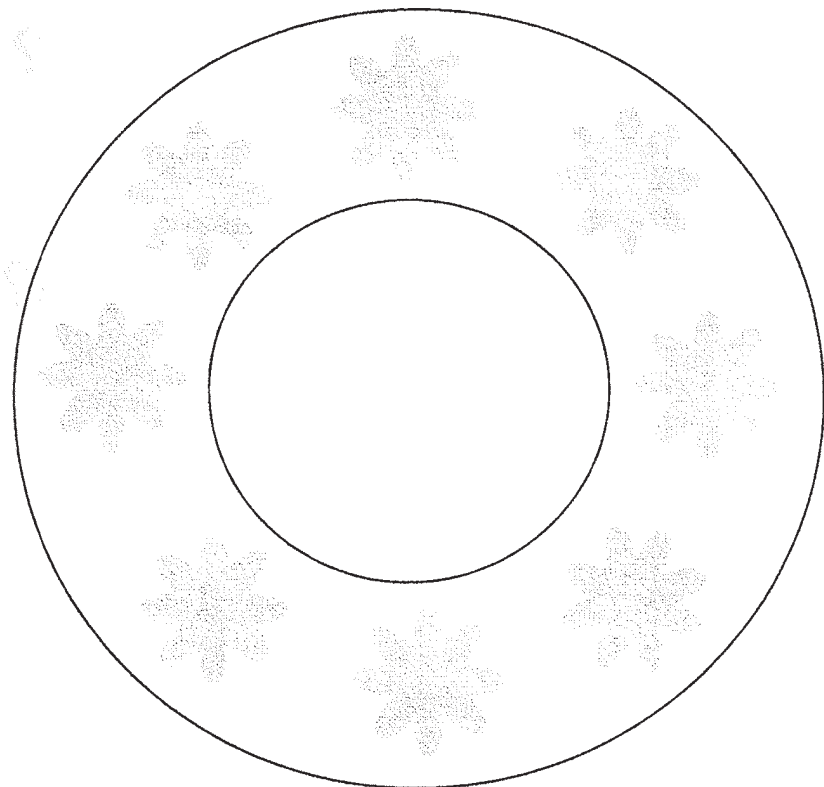
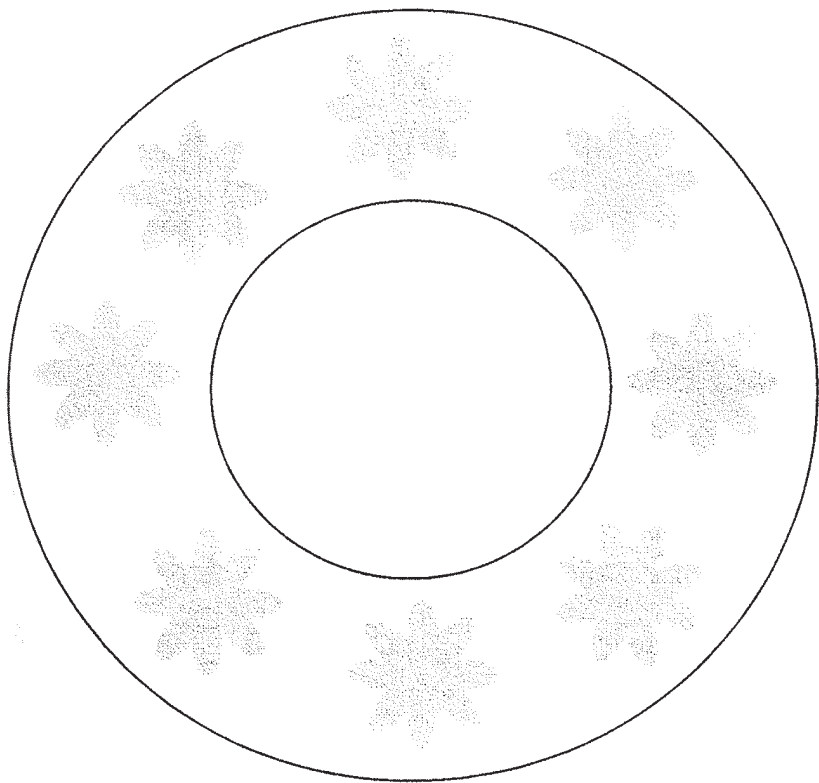

- b) Tegyéél mindkét tányérba egyenlő mennyiségű almát! Írd fel műveletként! \_\_\_\_\_
- c) Ha az egyikbe 4 almát teszel, mennyi hiányzik a másiktól, hogy összesen 9 alma legyen?  
\_\_\_\_\_
- d) Tegyéél az egyikbe 3 almát! Mennyit kell a másikba tenned, hogy összesen 8 alma legyen? \_\_\_\_\_
- e) Egyik tányérba tegyéél 10 almát! Hányat kell kivenned belőle, hogy 6 alma maradjon benne?  
\_\_\_\_\_
- f) Egyik tányérba tegyéél 10 almát! Hányat kell kivenned belőle, hogy 7 alma maradjon benne?  
\_\_\_\_\_
- g) Egyik tányérba tegyéél 10 almát! Hányat kell kivenned belőle, hogy 3 alma maradjon benne?  
\_\_\_\_\_
- h) Egyik tányérba tegyéél 10 almát! Hányat kell kivenned belőle, hogy 1 alma maradjon benne?  
\_\_\_\_\_
- i) Egyik tányérba tegyéél 10 almát! Hányat kell kivenned belőle, hogy 9 alma maradjon benne?  
\_\_\_\_\_

## Összeadás a 10-es számkörben

1. a)  $2+6=$        $3+7=$       b)  $2+7=$        $1+4=$   
 $7+3=$        $0+8=$        $3+1=$        $5+3=$   
 $0+4=$        $6+0=$        $1+8=$        $4+2=$   
 $4+3=$        $5+4=$        $5+5=$        $7+1=$   
 $9+1=$        $6+3=$        $10+0=$        $0+5=$   
 $7+2=$        $2+8=$        $4+5=$        $4+6=$   
 $4+4=$        $3+4=$        $2+5=$        $6+4=$

2. Egészítsd ki, hogy 10 legyen!

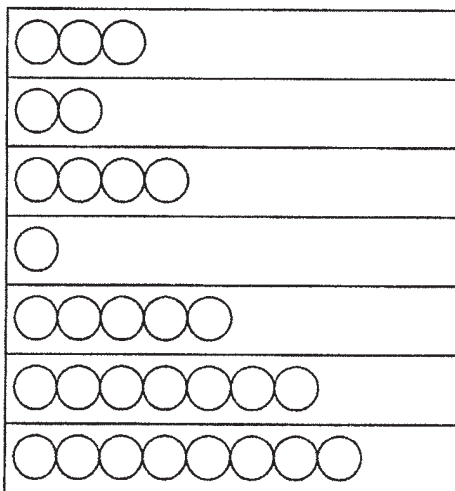

$3 + \cdot = \cdot$	$\cdot + 3 = \cdot$
$2 + \cdot = \cdot$	$\cdot + 2 = \cdot$
$\cdot + \cdot = \cdot$	$\cdot + \cdot = \cdot$
$\cdot + \cdot = \cdot$	$\cdot + \cdot = \cdot$
$\cdot + \cdot = \cdot$	$\cdot + \cdot = \cdot$
$\cdot + \cdot = \cdot$	$\cdot + \cdot = \cdot$
$\cdot + \cdot = \cdot$	$\cdot + \cdot = \cdot$

3. A kisjuhásznak 8 fehér és 2 fekete báránya volt. Hány báránya volt összesen?

.....

A 10 bárányt a hegyre vitte legeltetni. Ebből 3-at elvitt a farkas. Hány báránya maradt?

.....

Hűséges kutyája 2-t visszahozott a farkastól. Most hány báránya van?

.....

# Kivonás a 10-es számkörben

1.

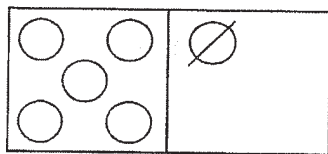

$$6 - \square = \square$$

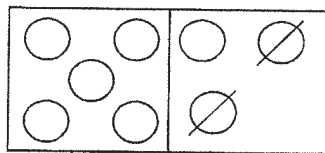

$$\square - \square = \square$$

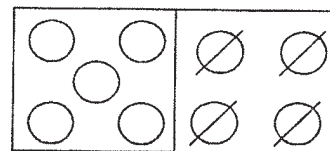

$$\square - \square = \square$$

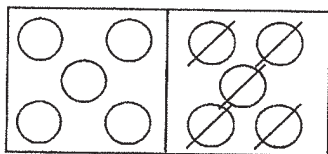

$$\square - \square = \square$$

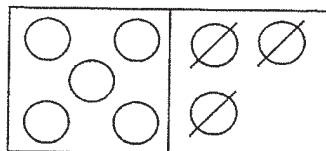

$$\square - \square = \square$$

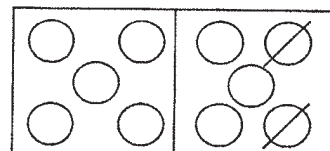

$$\square - \square = \square$$

2. Számítsd ki!

$8-6=$

$5-4=$

$9-5=$

$10-4=$

$8-2=$

$4-3=$

$10-6=$

$10-2=$

$9-1=$

$7-2=$

$9-7=$

$7-4=$

$6-3=$

$4-2=$

$6-4=$

$6-5=$

$8-3=$

$5-1=$

$7-1=$

$10-8=$

3. Az istállóban 9 tehén volt, ebből 7-et eladtak.  
Hány tehén maradt az istállóban?

\_\_\_\_\_

4. Egy héten hány napot jársz iskolába?  
Hány szabadnap marad?

\_\_\_\_\_

5. A tyúkanyó 10 tojáson ült. Ebből 3-at nem  
költött ki. Hány csibéje lett?

\_\_\_\_\_

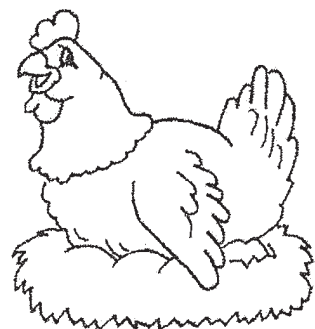

## 6. Válaszolj szóban!

Tízből elveszek egyet, az kilenc,

kilencből elveszek egyet, az ...

nyolcból elveszek egyet, az ...

Folytasd, amíg nulla nem lesz az eredmény!

7.

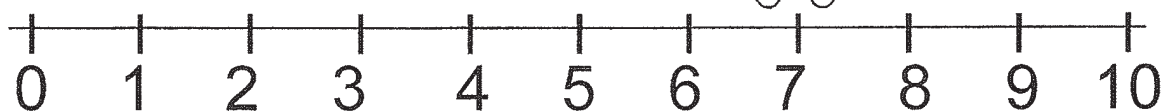

Hányat kell lépnie a macinak, hogy a

... kettesre érjen, \_\_\_\_\_

... tízesre érjen, \_\_\_\_\_

... négyesre érjen, \_\_\_\_\_

... nyolcasra érjen, \_\_\_\_\_

... kilencesre érjen? \_\_\_\_\_

## 8. Hasonlítsd össze a számokat!

Írd be a  $<$ ,  $>$ ,  $=$  jelet!

5	<input type="text"/>	5	6	<input type="text"/>	4	7	<input type="text"/>	3	2	<input type="text"/>	10
2	<input type="text"/>	4	10	<input type="text"/>	9	6	<input type="text"/>	4	6	<input type="text"/>	3
8	<input type="text"/>	9	1	<input type="text"/>	7	0	<input type="text"/>	1	8	<input type="text"/>	5
6	<input type="text"/>	6	8	<input type="text"/>	6	9	<input type="text"/>	10	7	<input type="text"/>	6
3	<input type="text"/>	8	5	<input type="text"/>	3	8	<input type="text"/>	8	3	<input type="text"/>	8
4	<input type="text"/>	2	8	<input type="text"/>	10	6	<input type="text"/>	7	4	<input type="text"/>	2
7	<input type="text"/>	4	6	<input type="text"/>	9	3	<input type="text"/>	4	6	<input type="text"/>	1

## Feladatok

1. a)  $3+2=$        $4+6=$        $5+0=$        $6+0=$   
 $3+3=$        $4+2=$        $5+2=$        $6+4=$   
 $3+4=$        $4+5=$        $5+4=$        $6+2=$   
 $3+5=$        $4+4=$        $5+3=$        $6+3=$

b)  $2+5=$        $7+3=$        $8+2=$        $9+0=$   
 $2+8=$        $7+2=$        $8+1=$        $9+1=$   
 $2+7=$        $7+1=$        $8+0=$        $0+9=$   
 $2+4=$        $7+0=$        $0+8=$        $1+9=$

c)  $6-4=$        $7-2=$        $8-4=$        $7-7=$   
 $6-2=$        $7-4=$        $8-2=$        $7-1=$   
 $6-3=$        $7-5=$        $8-5=$        $7-6=$   
 $6-5=$        $7-3=$        $8-0=$        $7-0=$

d)  $8-6=$        $8-5=$        $9-7=$        $9-1=$   
 $8-3=$        $8-8=$        $9-8=$        $9-0=$   
 $8-1=$        $9-2=$        $9-5=$        $9-9=$   
 $8-7=$        $9-3=$        $9-6=$        $9-4=$

e)  $10-6=$        $10-5=$        $10-1=$   
 $10-8=$        $10-3=$        $10-0=$   
 $10-7=$        $10-4=$        $10-2=$   
 $10-10=$        $10-9=$



## Sorszámok

1. a) Számold meg a tulipánokat!  
Első, második...

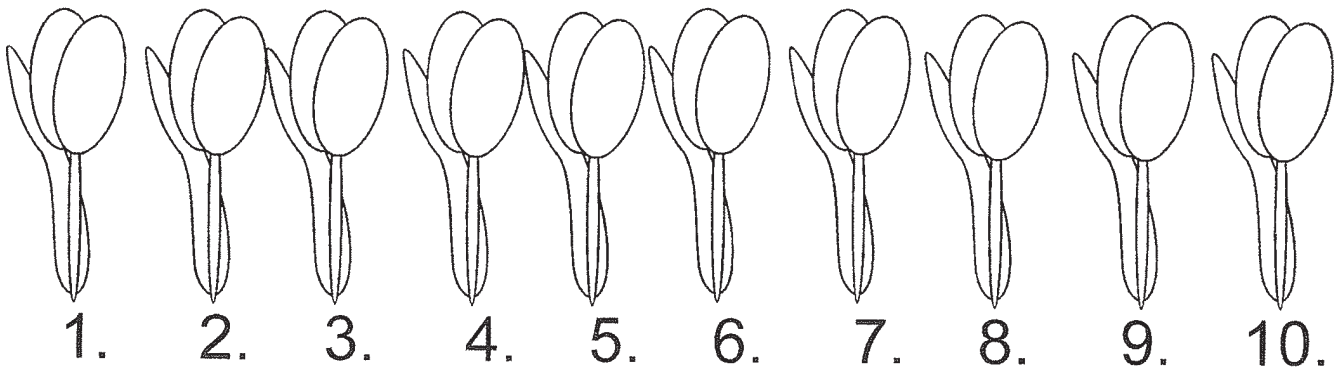

- b) Színezd ki a tulipánokat a következő képpen:

- az elsőt és a harmadikat pirosra,
- a negyediket és a hetediket citromsárgára,
- a másodikat, ötödiket és a kilencediket narancssárgára
- a hatodikat, nyolcadikat és a tizediket pedig lilára!

- c.) Felelj a következő kérdésekre!

1. Hanyadik az a tulipán, mely a két piros között van?
2. Hanyadik az a tulipán, mely a 6. és a 8. között van?
3. Milyen színű tulipán van a 4. és a 6. között?

Menj át a labirintuson!

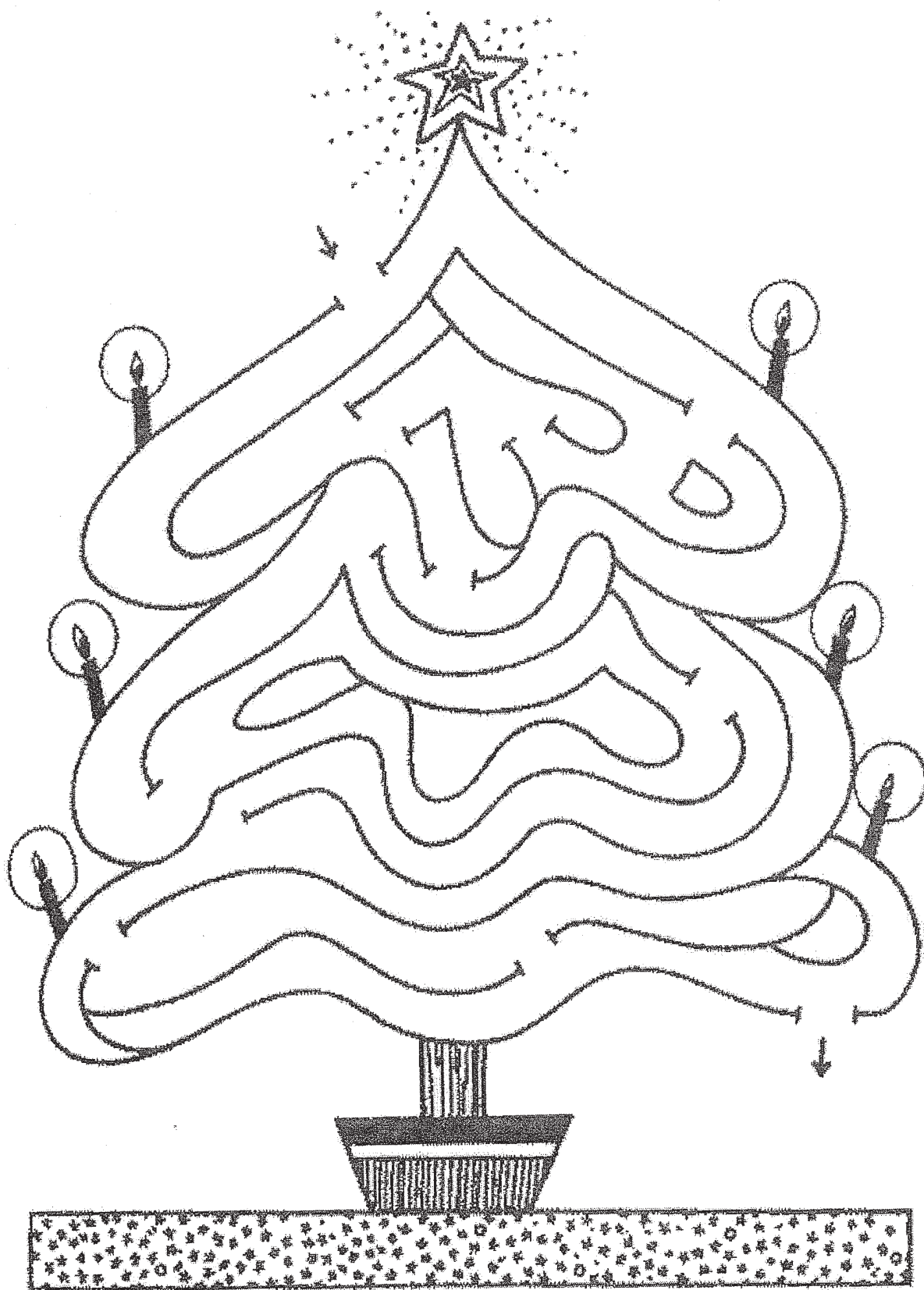

Rajzolj a fákra almát az utasítás szerint,

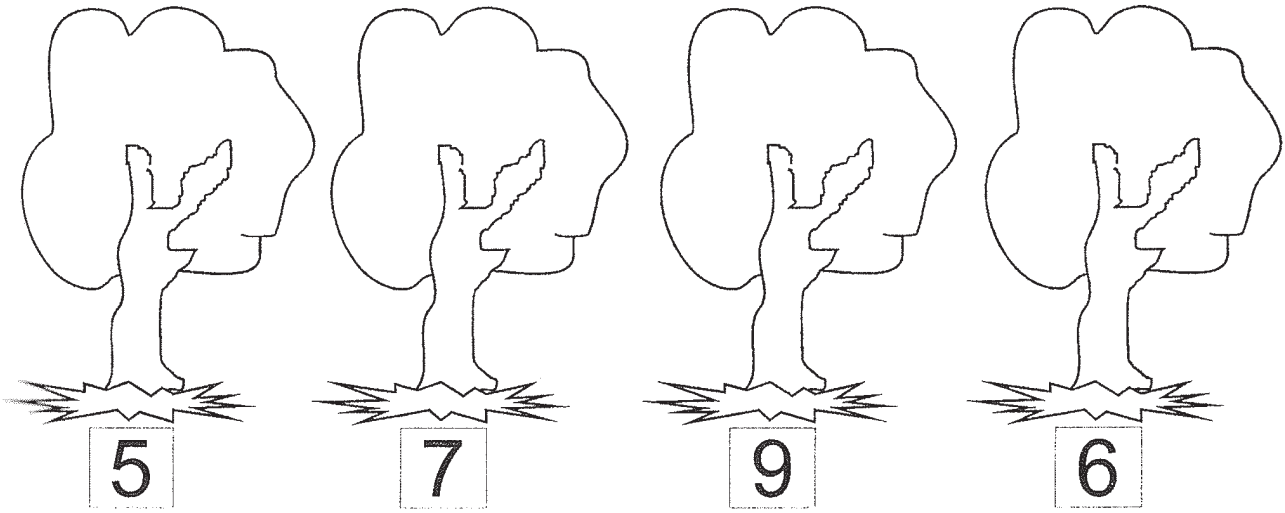

a vázákba virágot,

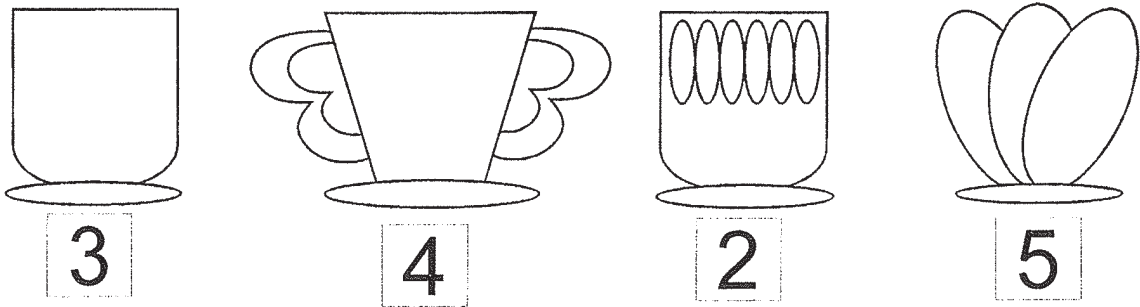

szőlőszemeket a levelekhez!

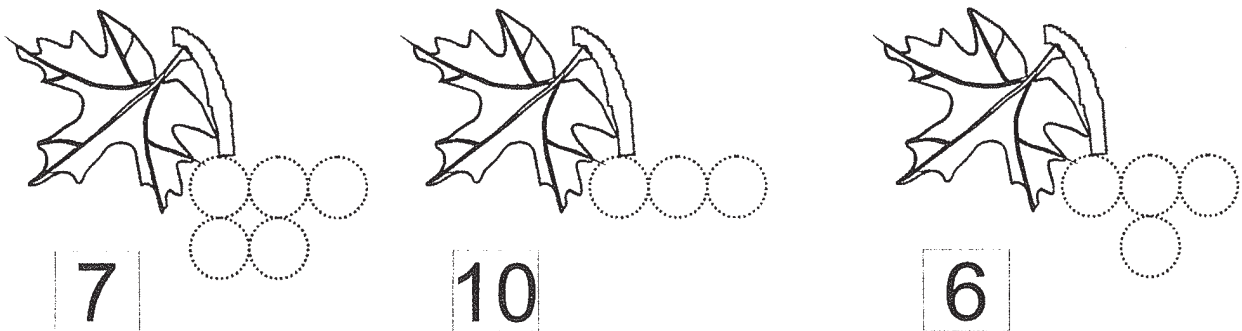

# Feladatok

1.

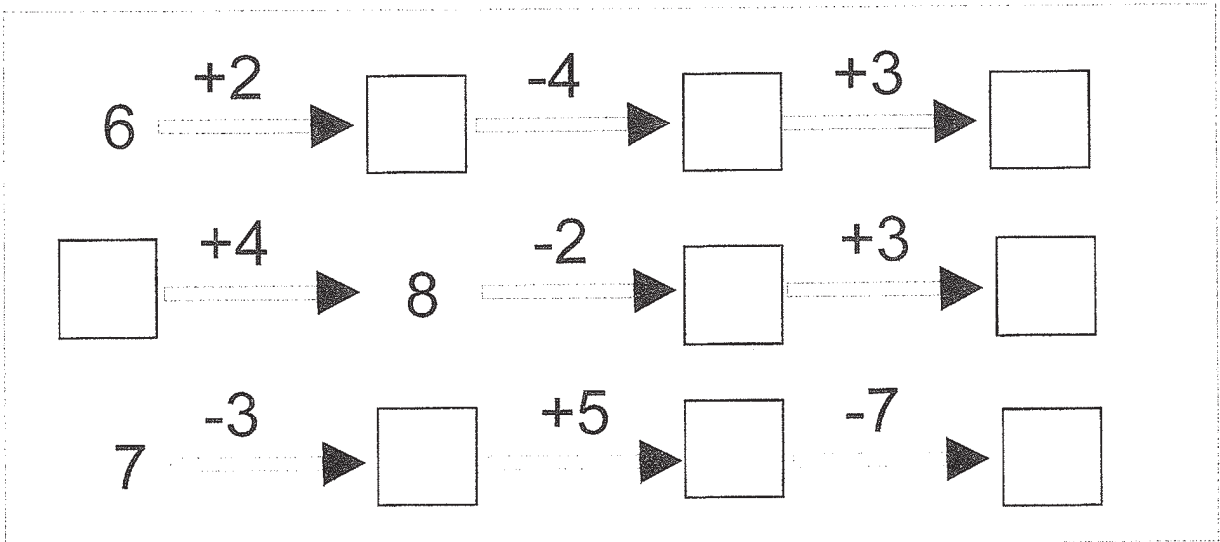

2.

Bontsd a 10-es számot háromfelé!  
Pótold a hiányzó számokat!

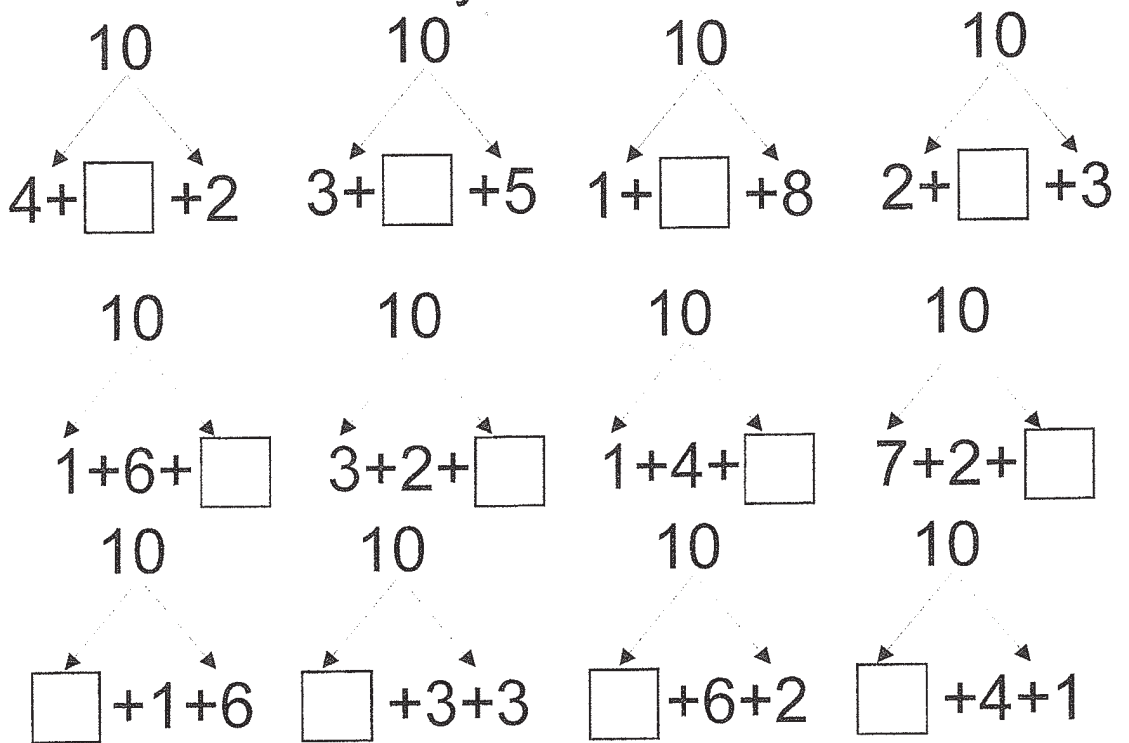

3.

A három szám összege legyen 10!

1	7		3	4	2	7		4	6	
2	1		6	1	4	1		8	1	

## Feladatok

1. a)

$9 + \cdot = 10$	$4 + \cdot = 10$	$\cdot + 1 = 10$
$8 + \cdot = 10$	$3 + \cdot = 10$	$\cdot + 2 = 10$
$7 + \cdot = 10$	$2 + \cdot = 10$	$\cdot + 3 = 10$
$6 + \cdot = 10$	$1 + \cdot = 10$	$\cdot + 4 = 10$
$5 + \cdot = 10$	$0 + \cdot = 10$	$\cdot + 5 = 10$

b)

$\cdot + 6 = 10$	$10 = 3 + \cdot$	$10 = 1 + \cdot$
$\cdot + 7 = 10$	$10 = 9 + \cdot$	$10 = 0 + \cdot$
$\cdot + 8 = 10$	$10 = 4 + \cdot$	$10 = 8 + \cdot$
$\cdot + 9 = 10$	$10 = 5 + \cdot$	$10 = 7 + \cdot$
$\cdot + 0 = 10$	$10 = 2 + \cdot$	$10 = 6 + \cdot$

2. a)

$3 - \cdot = 2$	$7 - \cdot = 3$	$8 - \cdot = 7$
$4 - \cdot = 1$	$6 - \cdot = 4$	$3 - \cdot = 0$
$5 - \cdot = 3$	$8 - \cdot = 2$	$7 - \cdot = 5$
$2 - \cdot = 0$	$10 - \cdot = 6$	$10 - \cdot = 2$
$1 - \cdot = 1$	$9 - \cdot = 5$	$10 - \cdot = 1$

b)

$7 - \cdot = 1$	$10 - 6 =$	$1 - 1 =$
$10 - \cdot = 4$	$10 - 7 =$	$6 - 5 =$
$8 - \cdot = 6$	$10 - 2 =$	$4 - 3 =$
$9 - \cdot = 7$	$10 - 3 =$	$7 - 2 =$
$6 - \cdot = 3$	$10 - 1 =$	$5 - 4 =$

c)

$9 - 6 =$	$10 - 2 =$	$7 - 6 =$
$8 - 5 =$	$9 - 4 =$	$7 - 5 =$
$7 - 4 =$	$6 - 2 =$	$8 - 8 =$

# A második tízes számai

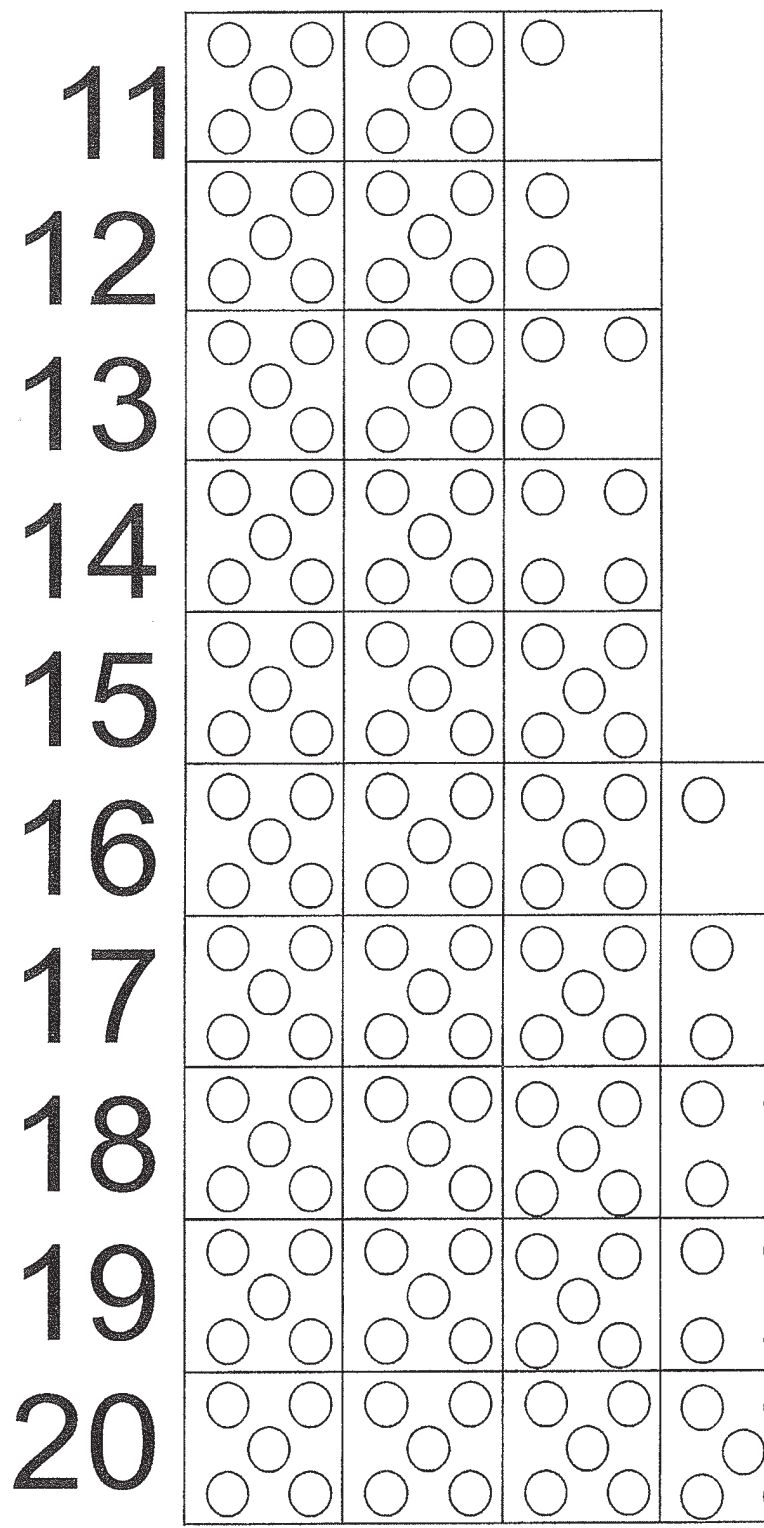
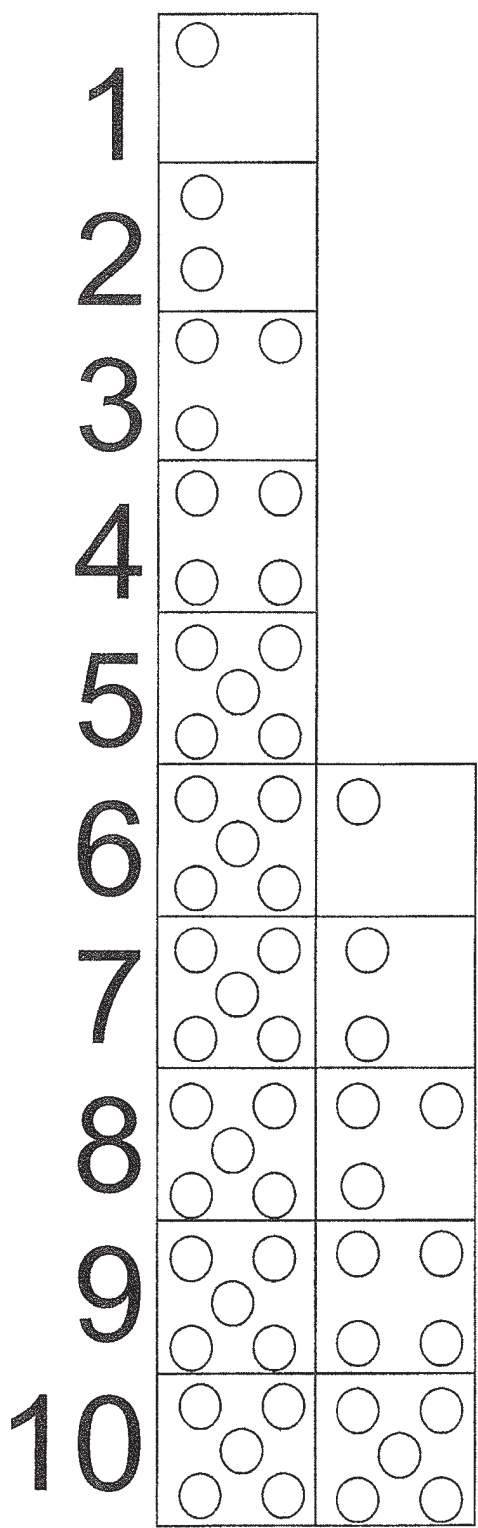
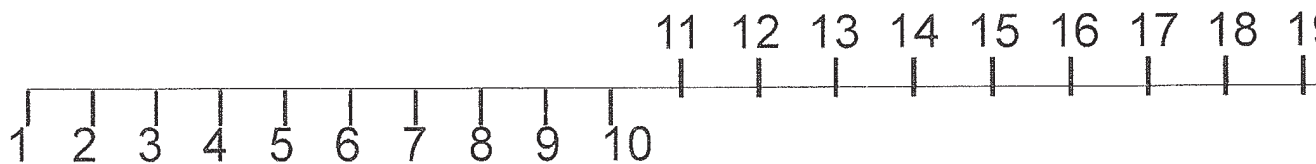

## Feladatok

1. Olvasd el a számokat!

10+1=11 tizenegy      10+  
10+2=12 tizenkettő      10+  
10+3=13 tizenhárom      10+  
10+4=14 tizennégy      10+  
10+5=15 tizenöt      10+  
10+6=16 tizenhat      10+  
10+7=17 tizenhét      10+  
10+8=18 tizennyolc      10+  
10+9=19 tizenkilenc      10+  
10+10=20 húsz      10+

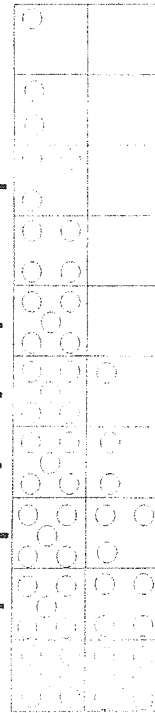

2. Az első tízesbe tartoznak a következő számok: \_\_\_\_\_  
a második tízesbe pedig a következő számok: \_\_\_\_\_

3. Írd le számjegyekkel!

tizenkettő	__	kilenc	__
tizenöt	__	tizenhat	__
húsz	__	nyolc	__
tizenhárom	__	tíz	__
tizennégy	__	tizenkilenc	__

4. Írd le betűvel a számjegyeket!

6	_____	16	_____
15	_____	5	_____
20	_____	13	_____
18	_____	19	_____

Vezesd el a kis állatokat a tökig  
20-tól 1-ig!



20

9

18

19

10

16

17

11

8

15

12

6

14

13

7

4

5

2

3

1





# Összeadás 11-ig

1. Old meg a műveletet!

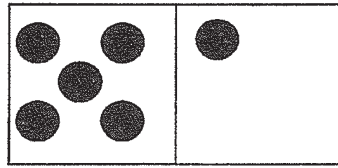
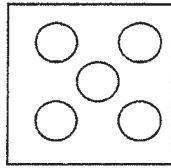

$$\boxed{5} + \boxed{6} = \boxed{\phantom{00}}$$

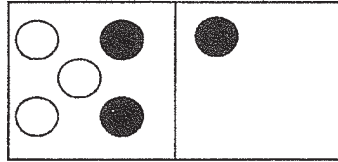
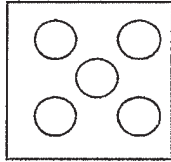

$$\boxed{\phantom{00}} + \boxed{\phantom{00}} = \boxed{\phantom{00}}$$

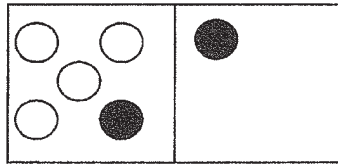
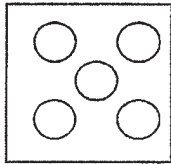

$$\boxed{\phantom{00}} + \boxed{\phantom{00}} = \boxed{\phantom{00}}$$

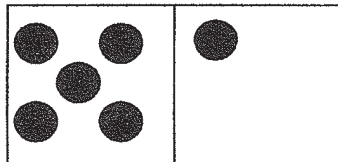
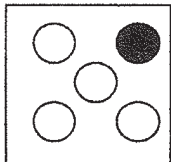

$$\boxed{\phantom{00}} + \boxed{\phantom{00}} = \boxed{\phantom{00}}$$

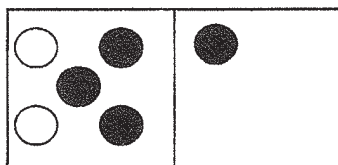
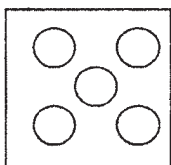

$$\boxed{\phantom{00}} + \boxed{\phantom{00}} = \boxed{\phantom{00}}$$

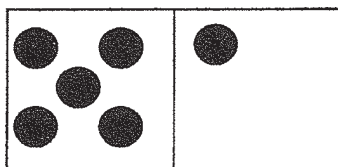
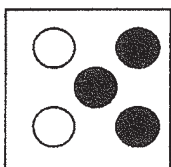

$$\boxed{\phantom{00}} + \boxed{\phantom{00}} = \boxed{\phantom{00}}$$

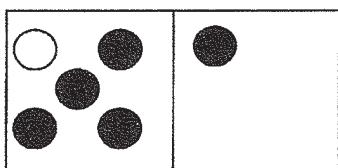
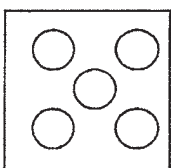

$$\boxed{\phantom{00}} + \boxed{\phantom{00}} = \boxed{\phantom{00}}$$

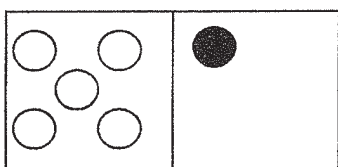
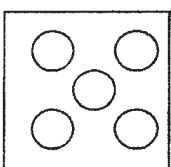

$$\boxed{\phantom{00}} + \boxed{\phantom{00}} = \boxed{\phantom{00}}$$

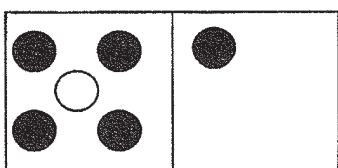
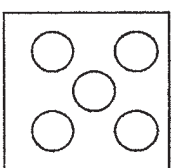

$$\boxed{\phantom{00}} + \boxed{\phantom{00}} = \boxed{\phantom{00}}$$

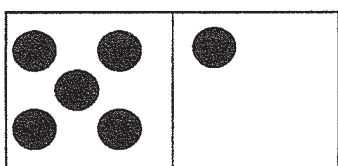
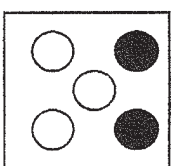

$$\boxed{\phantom{00}} + \boxed{\phantom{00}} = \boxed{\phantom{00}}$$



# Összeadás 11-ig

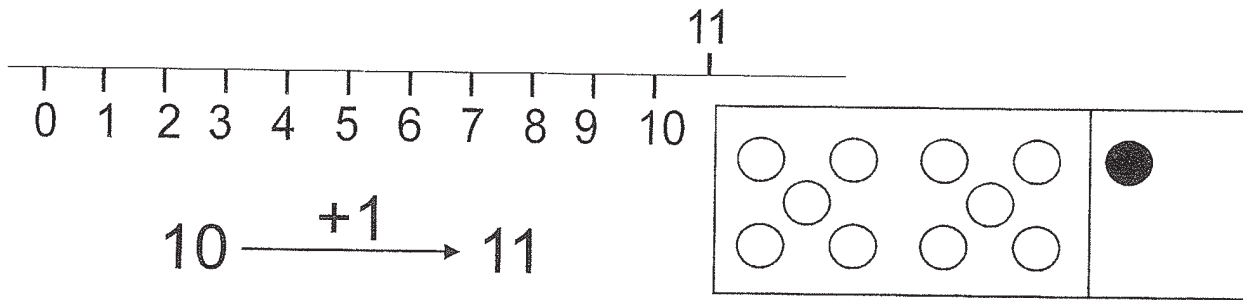

1. A polcon 9 könyv volt, és még 2 könyvet tehozzá. Hány könyv volt összesen a polcon?

$$9+2=$$

$$9+1+1=$$

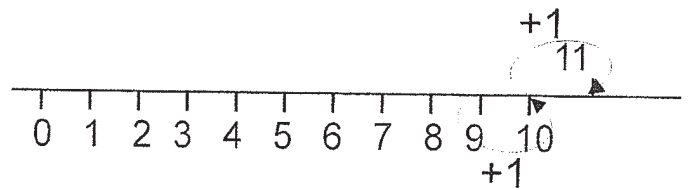

2. A dróton 7 fecske ült, azután pedig odarepült még 4. Összesen hány fecske ült a dróton?

$$7+4=$$

$$7+3+1=$$

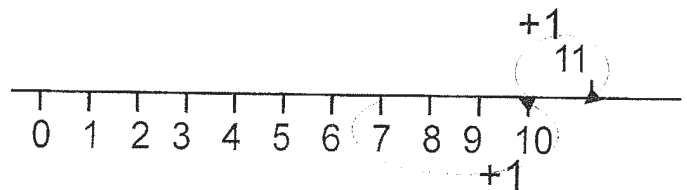

3. Írd fel összegként kétféleképpen!

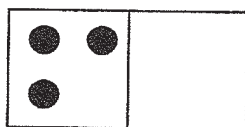
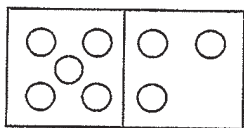

$$\square + \square = \square$$

$$\square + \square = \square$$

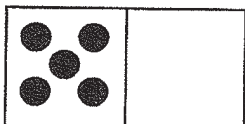
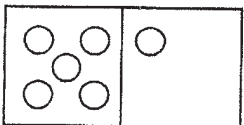

$$\square + \square = \square$$

$$\square + \square = \square$$

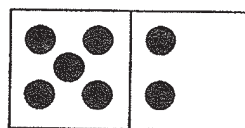
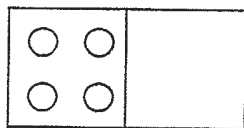

$$\square + \square = \square$$

$$\square + \square = \square$$

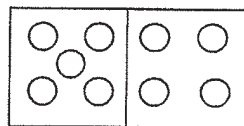

$$\square + \square = \square$$

$$\square + \square = \square$$

# Összeadás gyakorlása 11-ig

1.

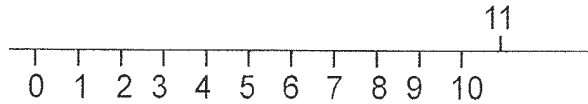

$$6+5=$$

$$6+4+1=$$

$$4+1$$

$$4+7=$$

$$4+ \cdot + \cdot =$$

$$\cdot + \cdot$$

$$7+4=$$

$$7+3+1=$$

$$3+1$$

$$3+8=$$

$$3+ \cdot + \cdot =$$

$$\cdot + \cdot$$

$$2+9=$$

$$2+1+ \cdot =$$

$$\cdot + \cdot$$

$$5+6=$$

$$5+ \cdot + \cdot =$$

$$\cdot + \cdot$$

$$8+3=$$

$$8+ \cdot + \cdot =$$

$$\cdot + \cdot$$

$$9+2=$$

$$9+ \cdot + \cdot =$$

$$\cdot + \cdot$$

2. Írd be a megfelelő  $<$ ,  $>$ ,  $=$  jelet!

$5+4$	<input type="checkbox"/>	11	$6+5$	<input type="checkbox"/>	9	$11$	<input type="checkbox"/>	$6+4$
$6+3$	<input type="checkbox"/>	10	$3+8$	<input type="checkbox"/>	11	$9$	<input type="checkbox"/>	$8+3$
$4+7$	<input type="checkbox"/>	11	$7+4$	<input type="checkbox"/>	8	$7$	<input type="checkbox"/>	$0+11$
$2+9$	<input type="checkbox"/>	10	$9+2$	<input type="checkbox"/>	10	$11$	<input type="checkbox"/>	$5+6$

3. Kati 4 gombócot evett, Vili pedig 7-et. Összesen hány gombócot ettek meg a gyerekek?

---

# Kivonás gyakorlása 11-ig

1. Sári gyöngyöket fűzött, és néhány szem a cénáról leesett. Hány maradt rajta?

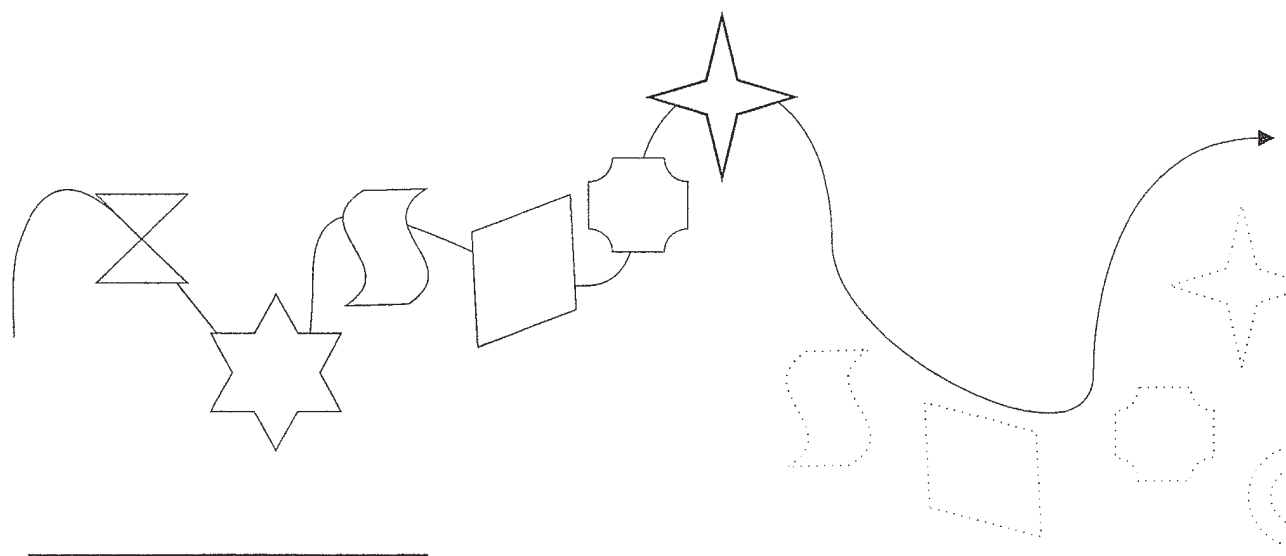
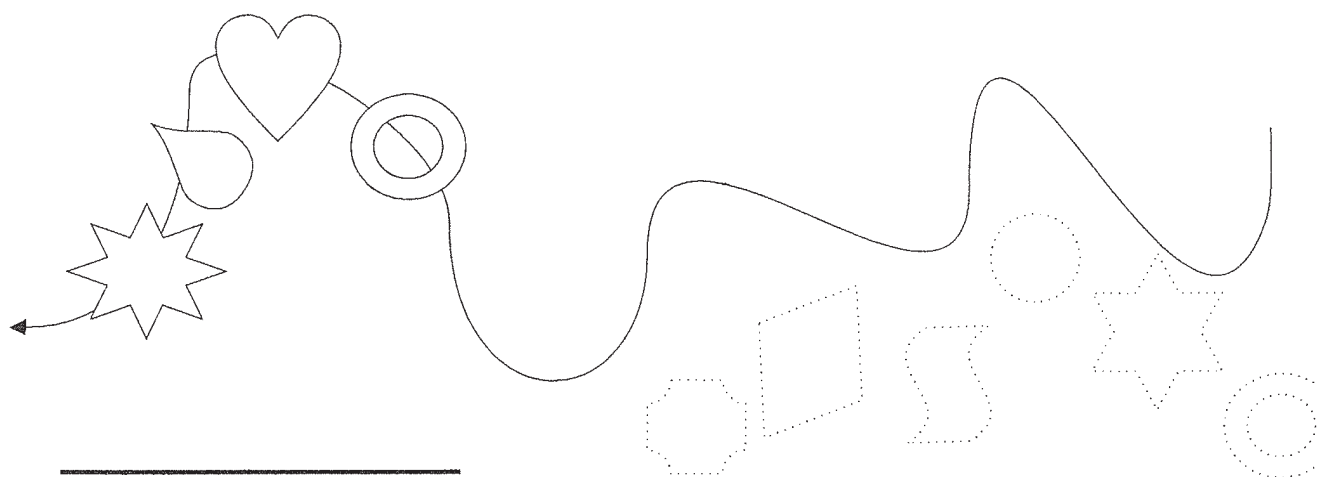
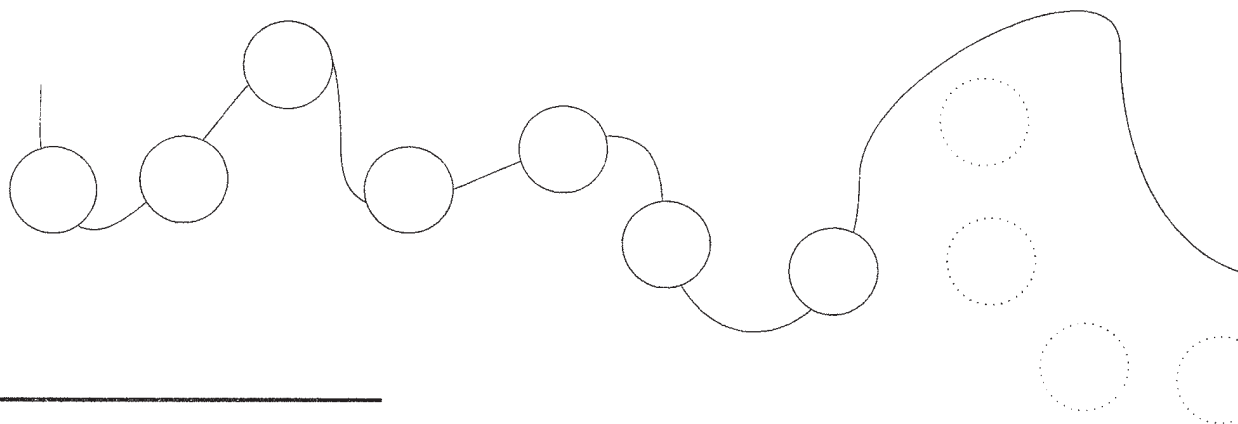

# Kivonás 11-ig

1. Old meg a műveletet!

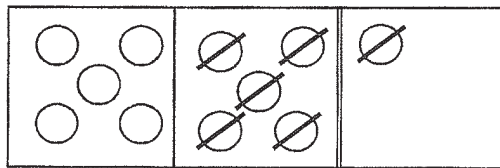

$$\boxed{11} - \square = \square$$

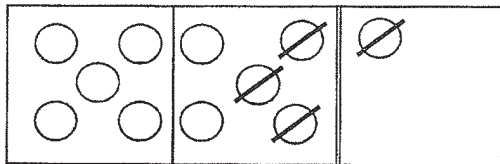

$$\square - \square = \square$$

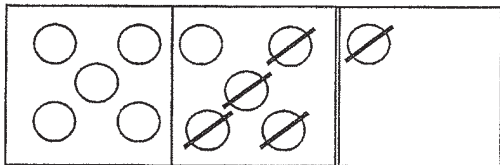

$$\square - \square = \square$$

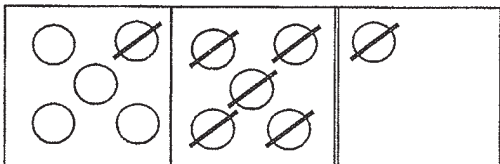

$$\square - \square = \square$$

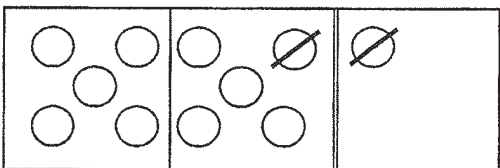

$$\square - \square = \square$$

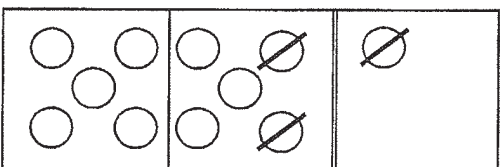

$$\square - \square = \square$$

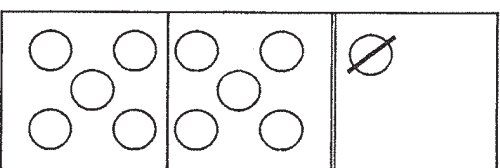

$$\square - \square = \square$$

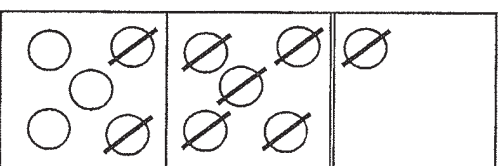

$$\square - \square = \square$$

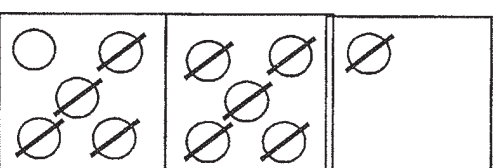

$$\square - \square = \square$$

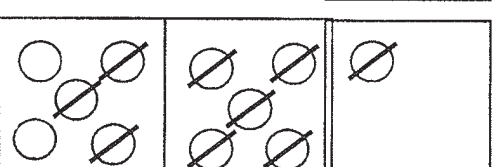

$$\square - \square = \square$$

## Kivonás gyakorlása 11-ig

1. a) A kotló alá 11 tojást tett a gazdasszony.  
Időközben 2 eltörött. Hány csibe kelt ki?



\_\_\_\_\_

- b) Imre polcán 11 könyv van. 3-at kölcsönad Péternek. Mennyi maradt a polcon?

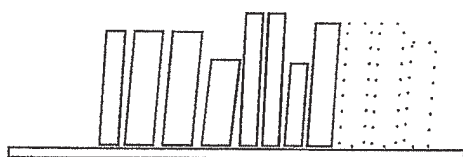

\_\_\_\_\_

- c) A dróton 11 fecske ült. 6 elrepült.  
Mennyi maradt ott?



\_\_\_\_\_

2. Pótold a hiányzó számokat!

$11 - \dots = 10$

$11 - \dots = 4$

$11 - \dots = 0$

$11 - \dots = 9$

$11 - \dots = 8$

$11 - \dots = 7$

$11 - \dots = 6$

$11 - \dots = 5$

$11 - \dots = 2$

3. Számold ki a kivonásokat!

$11 - 1 - 6 =$

$11 - 1 - 8 =$

$11 - 1 - 4 =$

$11 - 1 - 5 =$

$11 - 1 - 3 =$

$11 - 1 - 1 =$

$11 - 1 - 7 =$

$11 - 1 - 9 =$

$11 - 1 - 0 =$

$11 - 1 - 2 =$

# Összeadás 12-ig

1. Old meg a műveletet!

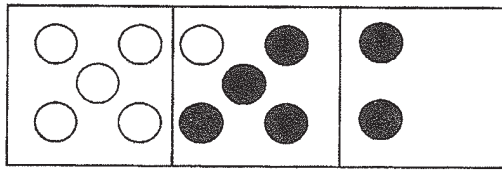

$$6 + 6 = \square$$

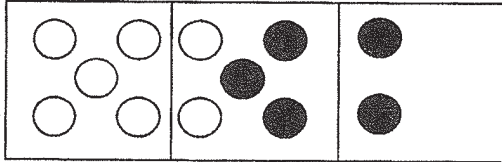

$$\square + \square = \square$$

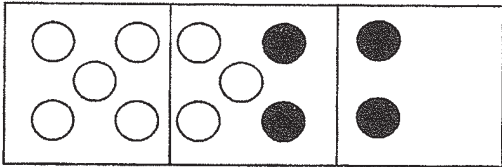

$$\square + \square = \square$$

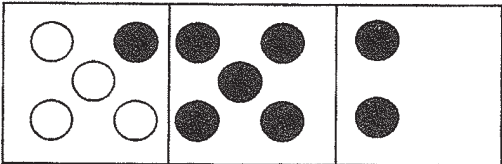

$$\square + \square = \square$$

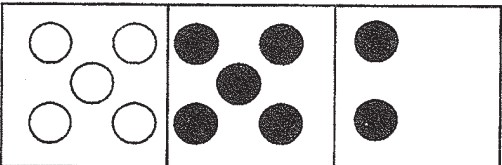

$$\square + \square = \square$$

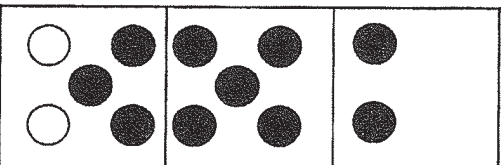

$$\square + \square = \square$$

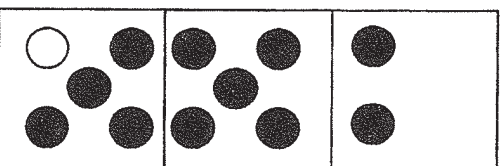

$$\square + \square = \square$$

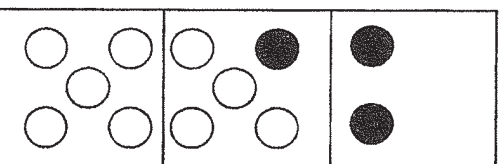

$$\square + \square = \square$$

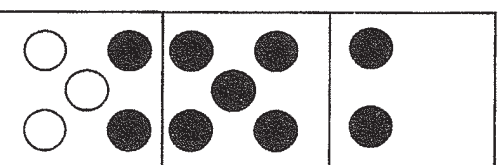

$$\square + \square = \square$$

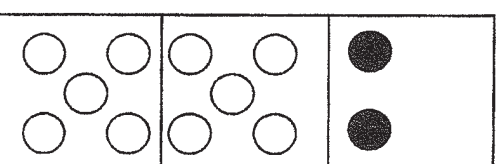

$$\square + \square = \square$$

# Összeadás 12-ig

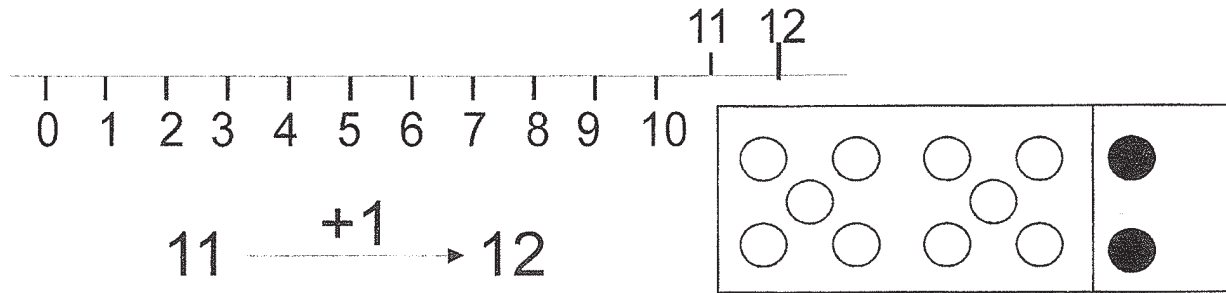

1. Feri játékdobozában 8 sárga és 4 kék üveggolyó van. Összesen hány golyó van a dobozban? Számolj!

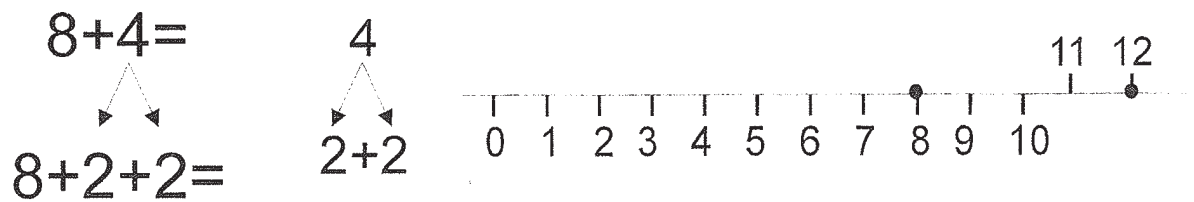

2. Jónásnak 5 fehér és 7 tarka kecskéje volt. Összesen hány kecskéje volt? Számolj!

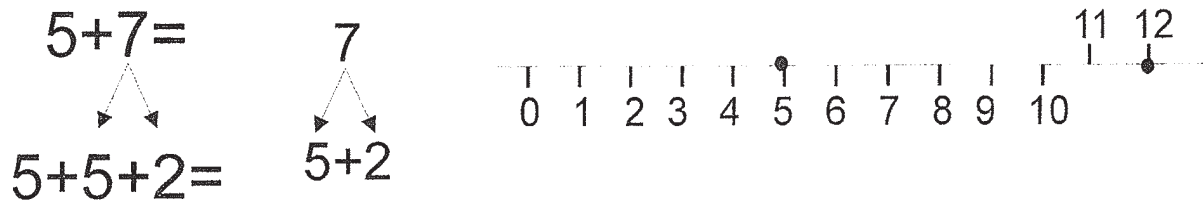

3. Számolj!

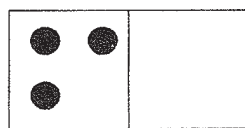
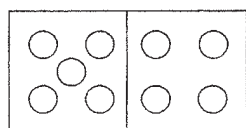

$\square + \square = \square$

$\square + \square = \square$

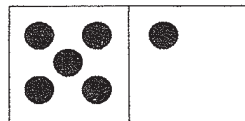
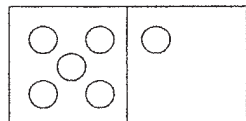

$\square + \square = \square$

$\square + \square = \square$

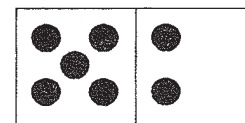
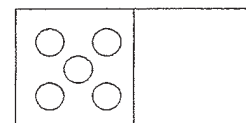

$\square + \square = \square$

$\square + \square = \square$

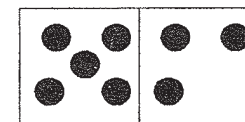
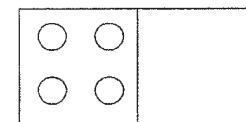

$\square + \square = \square$

$\square + \square = \square$



# Összeadás gyakorlása 12-ig

1. Peti kutyája délután 3 órán át szundikált, este pedig 9 órától reggel 6-ig aludt.  
Hány órát aludt összesen? \_\_\_\_\_

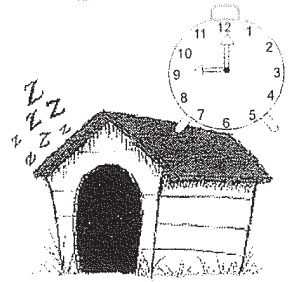

2. A repülőre először 4, azután pedig 8 utas szállt fel. Hányan utaztak együtt?  
\_\_\_\_\_

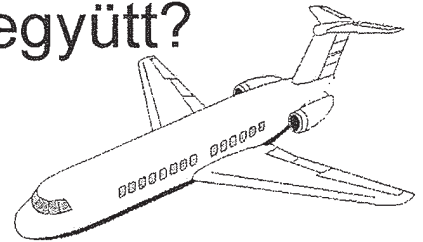

3. Old meg kétféleképp!

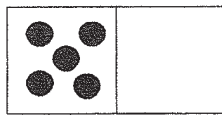
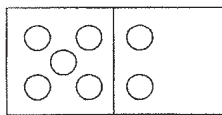

$\square + \square = \square$

$\square + \square = \square$

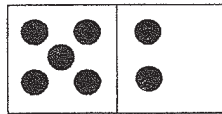
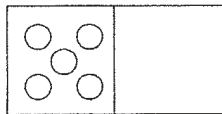

$\square + \square = \square$

$\square + \square = \square$

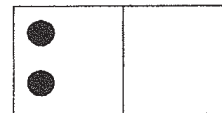
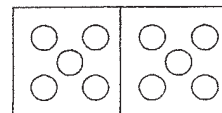

$\square + \square = \square$

$\square + \square = \square$

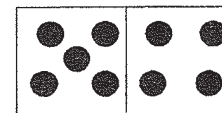
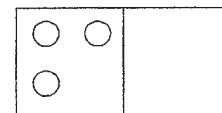

$\square + \square = \square$

$\square + \square = \square$

4.  $9+3=$        $5+7=$        $9+2=$   
 $8+4=$        $4+8=$        $5+6=$   
 $7+5=$        $3+9=$        $8+3=$   
 $6+6=$        $10+2=$        $4+7=$

5. Írd be a megfelelő  $<$ ,  $>$ ,  $=$  jelet!

$3+6 \square 9$

$2+7 \square 8$

$5+7 \square 9$

$4+5 \square 10$

$6+6 \square 11$

$9+2 \square 12$

$8+2 \square 11$

$4+8 \square 12$

$10+2 \square 11$

# Kivonás 12-ig

1. Old meg a műveletet!

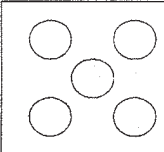
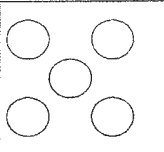
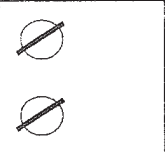
			<input type="text"/>	-	<input type="text"/>	=	<input type="text"/>
---	---	---	----------------------	---	----------------------	---	----------------------

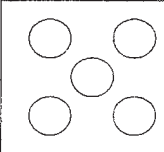
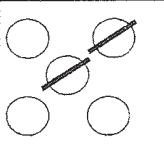
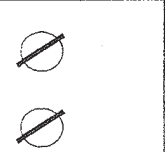
			<input type="text"/>	-	<input type="text"/>	=	<input type="text"/>
---	---	---	----------------------	---	----------------------	---	----------------------

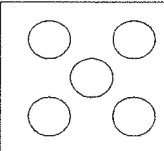
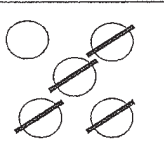
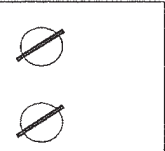
			<input type="text"/>	-	<input type="text"/>	=	<input type="text"/>
---	---	---	----------------------	---	----------------------	---	----------------------

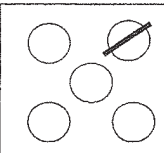
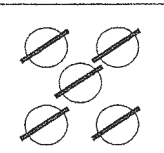
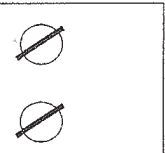
			<input type="text"/>	-	<input type="text"/>	=	<input type="text"/>
---	---	---	----------------------	---	----------------------	---	----------------------

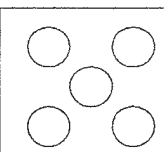
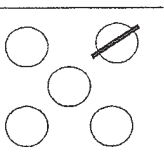
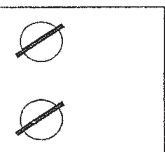
			<input type="text"/>	-	<input type="text"/>	=	<input type="text"/>
---	---	---	----------------------	---	----------------------	---	----------------------

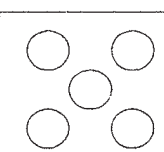
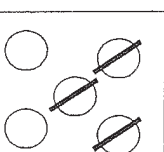
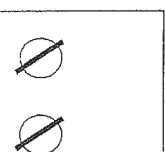
			<input type="text"/>	-	<input type="text"/>	=	<input type="text"/>
---	---	---	----------------------	---	----------------------	---	----------------------

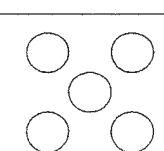
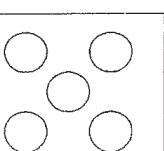
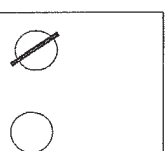
			<input type="text"/>	-	<input type="text"/>	=	<input type="text"/>
---	---	---	----------------------	---	----------------------	---	----------------------

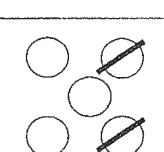
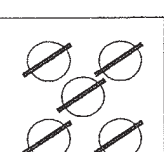
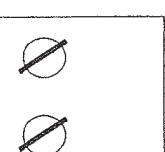
			<input type="text"/>	-	<input type="text"/>	=	<input type="text"/>
---	---	---	----------------------	---	----------------------	---	----------------------

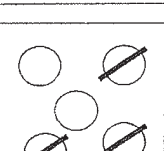
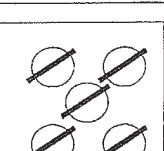
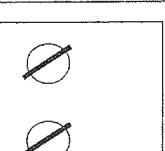
			<input type="text"/>	-	<input type="text"/>	=	<input type="text"/>
---	---	---	----------------------	---	----------------------	---	----------------------

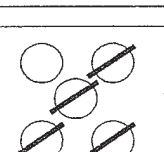
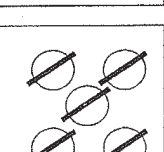
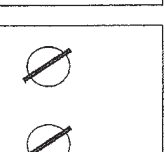
			<input type="text"/>	-	<input type="text"/>	=	<input type="text"/>
---	---	---	----------------------	---	----------------------	---	----------------------

# Kivonás 12-ig

1. a) Írd le a számokat visszafelé!

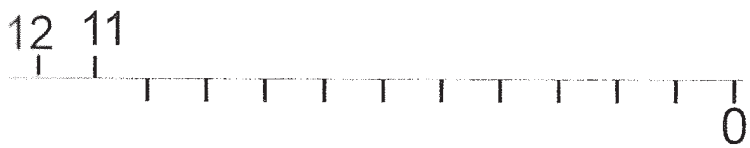

$$12 \xrightarrow{-2} 10$$

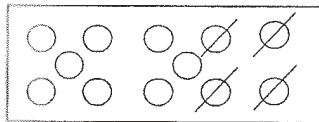

$$12-4=8$$

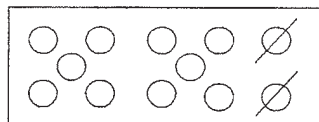

$$12-2=\square$$

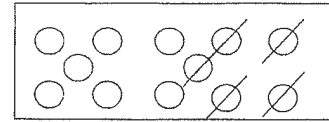

$$12-5=\square$$

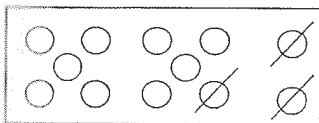

$$12-3=\square$$

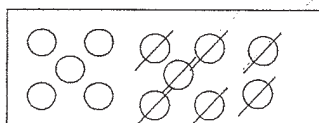

$$12-7=\square$$

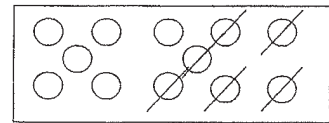

$$12-6=\square$$

b) Végezd el a kivonásokat bontással!

$$12-3=\square$$

$$3 \begin{array}{l} \swarrow \searrow \\ 2+1 \end{array}$$

$$12-2-1=\square$$

$$12-9=\square$$

$$9 \begin{array}{l} \swarrow \searrow \\ 2+7 \end{array}$$

$$12-2-7=\square$$

$$12-5=\square$$

$$5 \begin{array}{l} \swarrow \searrow \\ 2+\square \end{array}$$

$$12-2-\square=\square$$

$$12-2=\square$$

$$2 \begin{array}{l} \swarrow \searrow \\ 2+\square \end{array}$$

$$12-2-\square=\square$$

$$12-7=\square$$

$$7 \begin{array}{l} \swarrow \searrow \\ 2+\square \end{array}$$

$$12-\square-\square=\square$$

$$12-6=\square$$

$$6 \begin{array}{l} \swarrow \searrow \\ 2+\square \end{array}$$

$$12-\square-\square=\square$$

$$12-8=\square$$

$$8 \begin{array}{l} \swarrow \searrow \\ 2+\square \end{array}$$

$$12-\square-\square=\square$$

$$12-4=\square$$

$$4 \begin{array}{l} \swarrow \searrow \\ 2+\square \end{array}$$

$$12-\square-\square=\square$$

# Kivonás gyakorlása 12-ig

1. Írd le a számokat csökkenő sorrendben!

12

$$12 \xrightarrow{-1} 11$$

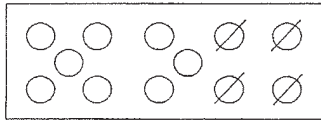

$12-4=8$

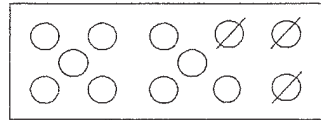

$12-3=\square$

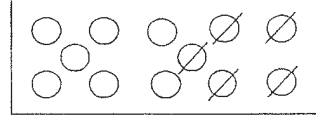

$12-5=\square$

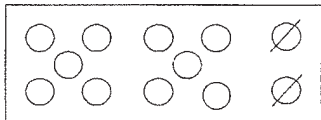

$12-2=\square$

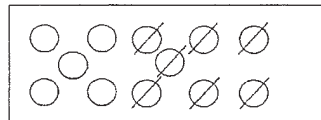

$12-7=\square$

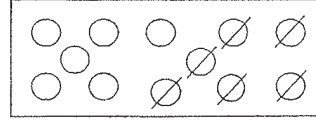

$12-6=\square$

b) Végezd el a kivonásokat bontással!

$$12-3=\square$$

$$12 \begin{array}{l} \nearrow \searrow \\ \rightarrow \leftarrow \end{array} \begin{array}{l} 2 \\ 1 \end{array} = \square$$

$$12-9=\square$$

$$12 \begin{array}{l} \nearrow \searrow \\ \rightarrow \leftarrow \end{array} \begin{array}{l} 2 \\ 7 \end{array} = \square$$

$$12-5=\square$$

$$12 \begin{array}{l} \nearrow \searrow \\ \rightarrow \leftarrow \end{array} \begin{array}{l} 2 \\ \square \end{array} = \square$$

$$12-2=\square$$

$$12 \begin{array}{l} \nearrow \searrow \\ \rightarrow \leftarrow \end{array} \begin{array}{l} \square \\ \square \end{array} = \square$$

$$12-7=\square$$

$$12 \begin{array}{l} \nearrow \searrow \\ \rightarrow \leftarrow \end{array} \begin{array}{l} \square \\ \square \end{array} = \square$$

$$12-6=\square$$

$$12 \begin{array}{l} \nearrow \searrow \\ \rightarrow \leftarrow \end{array} \begin{array}{l} \square \\ \square \end{array} = \square$$

$$12-8=\square$$

$$12 \begin{array}{l} \nearrow \searrow \\ \rightarrow \leftarrow \end{array} \begin{array}{l} \square \\ \square \end{array} = \square$$

$$12-4=\square$$

$$12 \begin{array}{l} \nearrow \searrow \\ \rightarrow \leftarrow \end{array} \begin{array}{l} \square \\ \square \end{array} = \square$$

# Összeadás 13-ig

1. Old meg a műveletet!

			$6 + 7 = \square$
--	--	--	-------------------

			$\square + \square = \square$
--	--	--	-------------------------------

			$\square + \square = \square$
--	--	--	-------------------------------

			$\square + \square = \square$
--	--	--	-------------------------------

			$\square + \square = \square$
--	--	--	-------------------------------

			$\square + \square = \square$
--	--	--	-------------------------------

			$\square + \square = \square$
--	--	--	-------------------------------

			$\square + \square = \square$
--	--	--	-------------------------------

			$\square + \square = \square$
--	--	--	-------------------------------

			$\square + \square = \square$
--	--	--	-------------------------------

# Műveletek gyakorlása 13-ig

1. Balu és Maugli banánt szedett ebédre. Balu 8-at, Maugli pedig 5-öt evett meg. Hány banán fogyott el?



2. Old meg kétféleképpen!

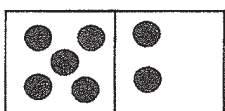
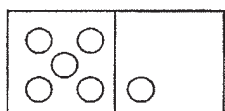

$6 + \square = \square$

$7 + \square = \square$

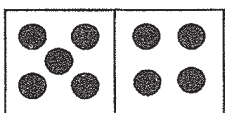
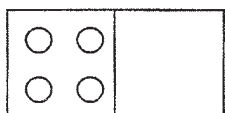

$\square + \square = \square$

$\square + \square = \square$

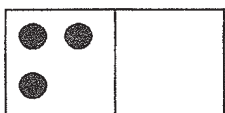
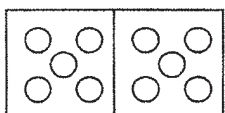

$\square + \square = \square$

$\square + \square = \square$

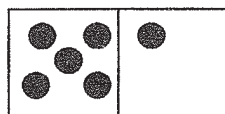
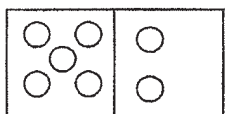

$\square + \square = \square$

$\square + \square = \square$

3.  $9+4=$        $6+7=$        $11+2=$        $13-6=$   
 $7+4=$        $4+9=$        $5+6=$        $13-4=$   
 $7+6=$        $4+8=$        $9+3=$        $13-7=$   
 $6+4=$        $10+3=$        $12+1=$        $12-6=$   
 $3+9=$        $6+5=$        $4+7=$        $12-8=$

4. Írd be a megfelelő  $<$ ,  $>$ ,  $=$  jelet!

$3+6 \square 9$

$2+7 \square 8$

$5+7 \square 13$

$4+5 \square 10$

$6+6 \square 11$

$9+2 \square 12$

$8+3 \square 13$

$5+8 \square 12$

$10+2 \square 11$

$13-4 \square 8$

$12-5 \square 7$

$13-6 \square 9$

# Kivonás 13-ig

## 1. Old meg a műveletet!

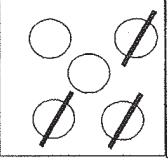
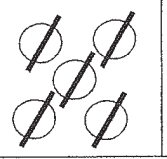
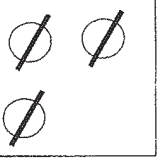
			<input type="text"/>	-	<input type="text"/>	=	<input type="text"/>
---	---	---	----------------------	---	----------------------	---	----------------------

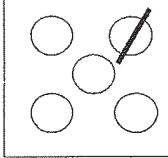
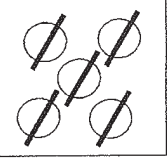
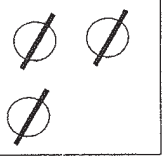
			<input type="text"/>	-	<input type="text"/>	=	<input type="text"/>
---	---	---	----------------------	---	----------------------	---	----------------------

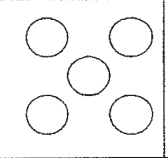
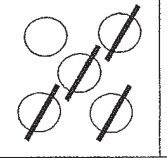
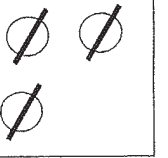
			<input type="text"/>	-	<input type="text"/>	=	<input type="text"/>
---	---	---	----------------------	---	----------------------	---	----------------------

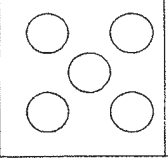
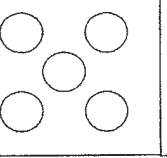
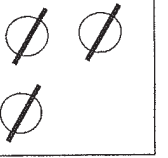
			<input type="text"/>	-	<input type="text"/>	=	<input type="text"/>
--	--	--	----------------------	---	----------------------	---	----------------------

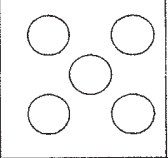
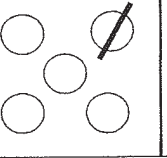
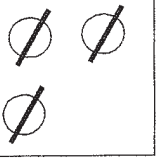
			<input type="text"/>	-	<input type="text"/>	=	<input type="text"/>
---	---	---	----------------------	---	----------------------	---	----------------------

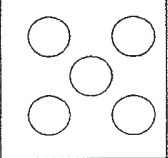
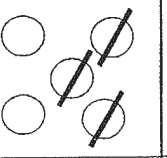
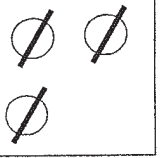
			<input type="text"/>	-	<input type="text"/>	=	<input type="text"/>
---	---	---	----------------------	---	----------------------	---	----------------------

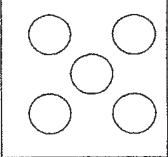
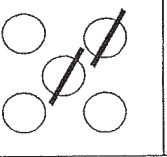
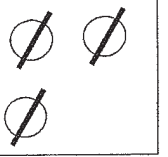
			<input type="text"/>	-	<input type="text"/>	=	<input type="text"/>
---	---	---	----------------------	---	----------------------	---	----------------------

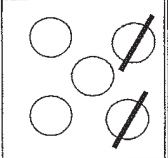
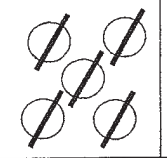
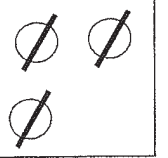
			<input type="text"/>	-	<input type="text"/>	=	<input type="text"/>
---	---	---	----------------------	---	----------------------	---	----------------------

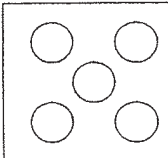
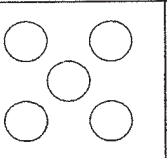
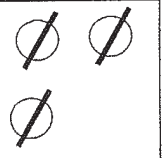
			<input type="text"/>	-	<input type="text"/>	=	<input type="text"/>
---	---	---	----------------------	---	----------------------	---	----------------------

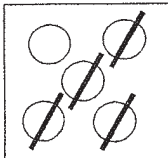
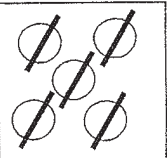
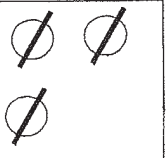
			<input type="text"/>	-	<input type="text"/>	=	<input type="text"/>
---	---	---	----------------------	---	----------------------	---	----------------------

# Kivonás gyakorlása 13-ig

$$13 \xrightarrow{-1} 12$$

1. a) Írd le a számokat csökkenő sorrendben

**13** □□ □□ □□ □ □ □ □ □ □ □ □ □ □

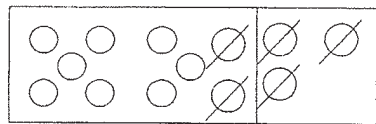

$$13 - 5 = 8$$

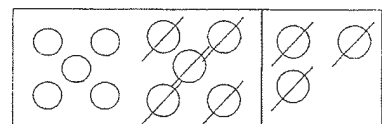

$$13 - 8 = \square$$

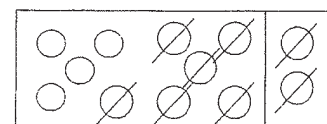

$$13 - 9 = \square$$

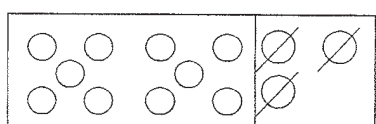

$$13 - 3 = \square$$

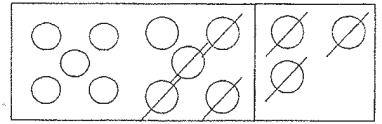

$$13 - 7 = \square$$

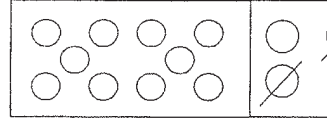

$$13 - 2 = \square$$

b) Végezd el a kivonásokat bontással!

$$13 - 3 = \square$$

$$13 - 3 - 0 = \square$$

$$13 - 9 = \square$$

$$13 - 3 - \square = \square$$

$$13 - 5 = \square$$

$$13 - 3 - \square = \square$$

$$13 - 4 = \square$$

$$13 - \square - \square = \square$$

$$13 - 8 = \square$$

$$13 - \square - \square = \square$$

$$13 - 6 = \square$$

$$13 - \square - \square = \square$$

$$13 - 7 = \square$$

$$13 - \square - \square = \square$$



# Összeadás 14-ig

1. Old meg a műveletet!

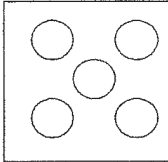
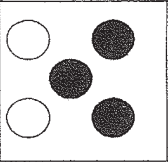
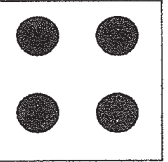
			$7 + 7 = \square$
---	---	---	-------------------

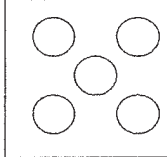
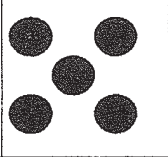
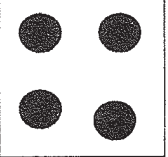
			$\square + \square = \square$
---	---	---	-------------------------------

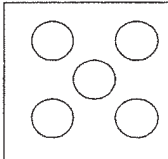
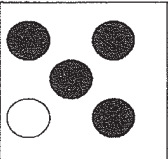
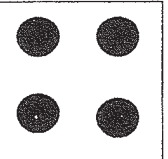
			$\square + \square = \square$
---	---	---	-------------------------------

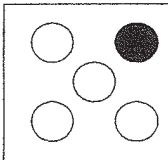
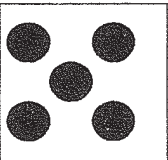
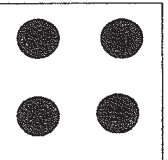
			$\square + \square = \square$
---	---	---	-------------------------------

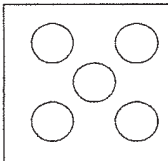
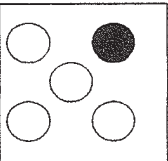
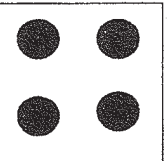
			$\square + \square = \square$
--	--	--	-------------------------------

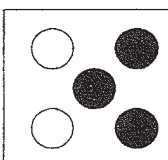
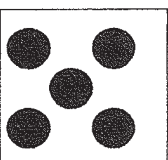
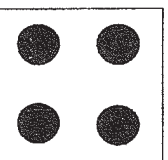
			$\square + \square = \square$
---	---	---	-------------------------------

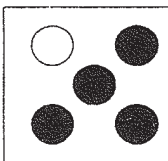
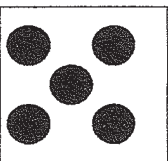
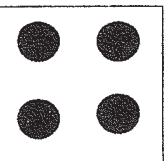
			$\square + \square = \square$
---	---	---	-------------------------------

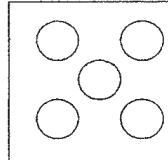
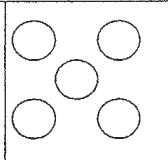
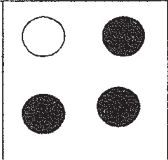
			$\square + \square = \square$
---	---	---	-------------------------------

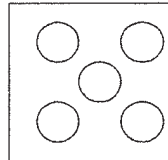
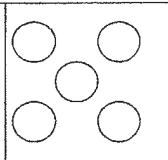
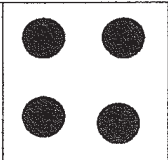
			$\square + \square = \square$
---	---	---	-------------------------------

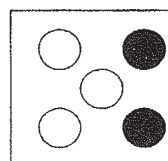
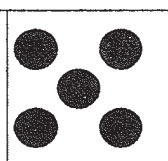
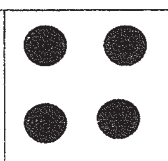
			$\square + \square = \square$
---	---	---	-------------------------------

# Kivonás 14-ig

1. Old meg a műveletet!

			$14 - \square = \square$
--	--	--	--------------------------

			$\square - \square = \square$
--	--	--	-------------------------------

			$\square - \square = \square$
--	--	--	-------------------------------

			$\square - \square = \square$
--	--	--	-------------------------------

			$\square - \square = \square$
--	--	--	-------------------------------

			$\square - \square = \square$
--	--	--	-------------------------------

			$\square - \square = \square$
--	--	--	-------------------------------

			$\square - \square = \square$
--	--	--	-------------------------------

			$\square - \square = \square$
--	--	--	-------------------------------

			$\square - \square = \square$
--	--	--	-------------------------------

# Műveletek gyakorlása 14-ig

1. A kis méhecske kosárkába virágport gyűjtött. 9 piros virágról és 5 sárga virágról szedte az illatos port. Összesen hány virágról gyűjtött a kosarába? \_\_\_\_\_



2. A kis méhecske barátjával ment virágport gyűjteni. Mindketten hét-hét virágról szedtek. Összesen hány virágról gyűjtöttek? \_\_\_\_\_

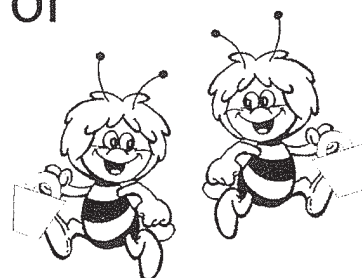

3. Old meg kétféleképpen!

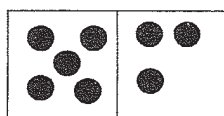
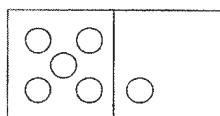

$\square + \square = \square$

$\square + \square = \square$

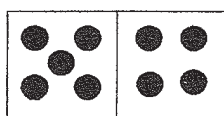
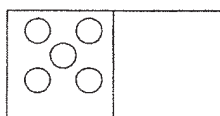

$\square + \square = \square$

$\square + \square = \square$

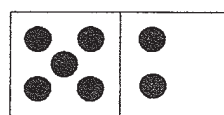
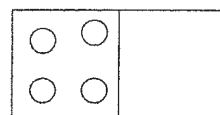

$\square + \square = \square$

$\square + \square = \square$

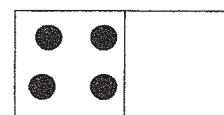
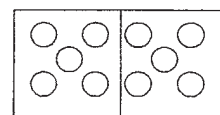

$\square + \square = \square$

$\square + \square = \square$

4. Számold ki!

$9+5=$

$4+7=$

$13+1=$

$10+2=$

$8+4=$

$5+9=$

$8+6=$

$10+4=$

$7+7=$

$4+8=$

$9+3=$

$7+5=$

$6+6=$

$10+1=$

$11+1=$

$4+7=$

5. Írd be a megfelelő  $<$ ,  $>$ ,  $=$  jelet!

$3+2 \square 8$

$12+7 \square 8$

$3+7 \square 10$

$7+7 \square 12$

$4+6 \square 11$

$9+5 \square 12$

$8+4 \square 11$

$4+9 \square 12$

$11+2 \square 14$

# Összeadás 15-ig

1. Old meg a műveletet!

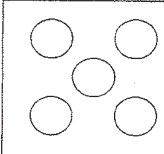
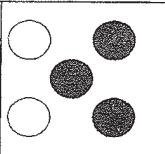
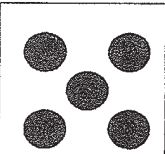
			$7 + 8 = \square$
---	---	---	-------------------

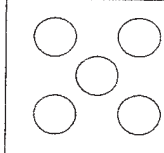
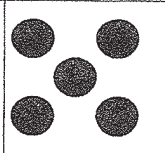
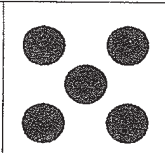
			$\square + \square = \square$
---	---	---	-------------------------------

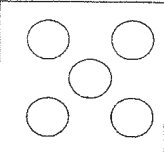
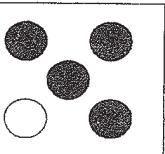
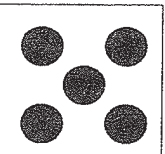
			$\square + \square = \square$
---	---	---	-------------------------------

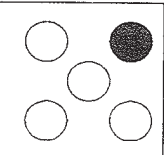
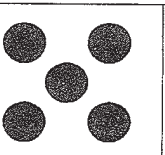
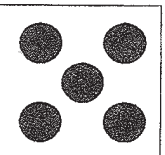
			$\square + \square = \square$
---	---	---	-------------------------------

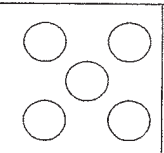
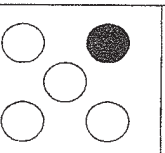
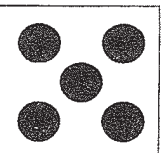
			$\square + \square = \square$
---	---	---	-------------------------------

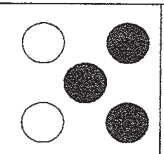
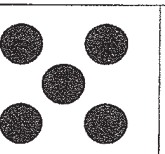
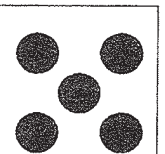
			$\square + \square = \square$
---	---	---	-------------------------------

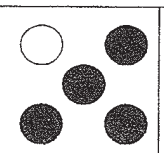
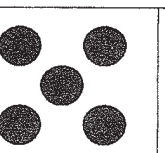
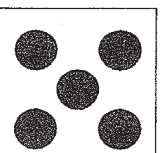
			$\square + \square = \square$
---	---	---	-------------------------------

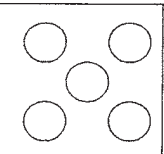
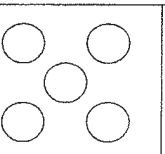
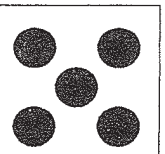
			$\square + \square = \square$
---	---	---	-------------------------------

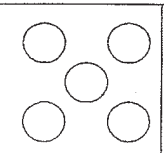
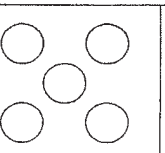
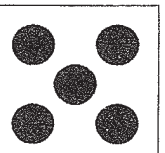
			$\square + \square = \square$
---	---	---	-------------------------------

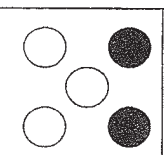
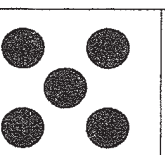
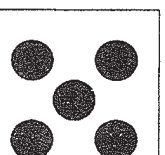
			$\square + \square = \square$
---	---	---	-------------------------------

# Kivonás 15-ig

1. Old meg a műveletet!

			$15 - \square = \square$
--	--	--	--------------------------

			$\square - \square = \square$
--	--	--	-------------------------------

			$\square - \square = \square$
--	--	--	-------------------------------

			$\square - \square = \square$
--	--	--	-------------------------------

			$\square - \square = \square$
--	--	--	-------------------------------

			$\square - \square = \square$
--	--	--	-------------------------------

			$\square - \square = \square$
--	--	--	-------------------------------

			$\square - \square = \square$
--	--	--	-------------------------------

			$\square - \square = \square$
--	--	--	-------------------------------

			$\square - \square = \square$
--	--	--	-------------------------------

# Műveletek gyakorlása 15-ig

1. Old meg kétféleképpen!

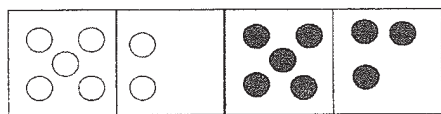

$\square + \square = \square$

$\square + \square = \square$

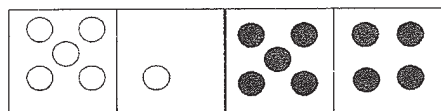

$\square + \square = \square$

$\square + \square = \square$

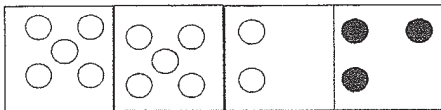

$\square + \square = \square$

$\square + \square = \square$

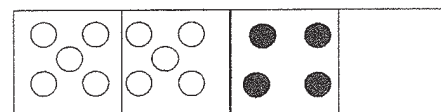

$\square + \square = \square$

$\square + \square = \square$

2. Számold ki!

$9+6=$

$3+7=$

$13+2=$

$10+3=$

$8+7=$

$6+9=$

$8+4=$

$10+5=$

$9+3=$

$5+8=$

$9+2=$

$7+6=$

$8+6=$

$14+1=$

$11+3=$

$5+7=$

3. a) Írd be a megfelelő  $<$ ,  $>$ ,  $=$  jelet!

$9+2 \square 12$

$12+2 \square 13$

$13+2 \square 14$

$7+5 \square 13$

$6+6 \square 11$

$9+5 \square 15$

$8+6 \square 14$

$6+9 \square 15$

$10+2 \square 13$

b)

$12-6 \square 9$

$15-9 \square 3$

$14-3 \square 11$

$12-7 \square 5$

$15-8 \square 7$

$11-5 \square 4$

$14-7 \square 6$

$15-6 \square 8$



$11-2 \square 8$

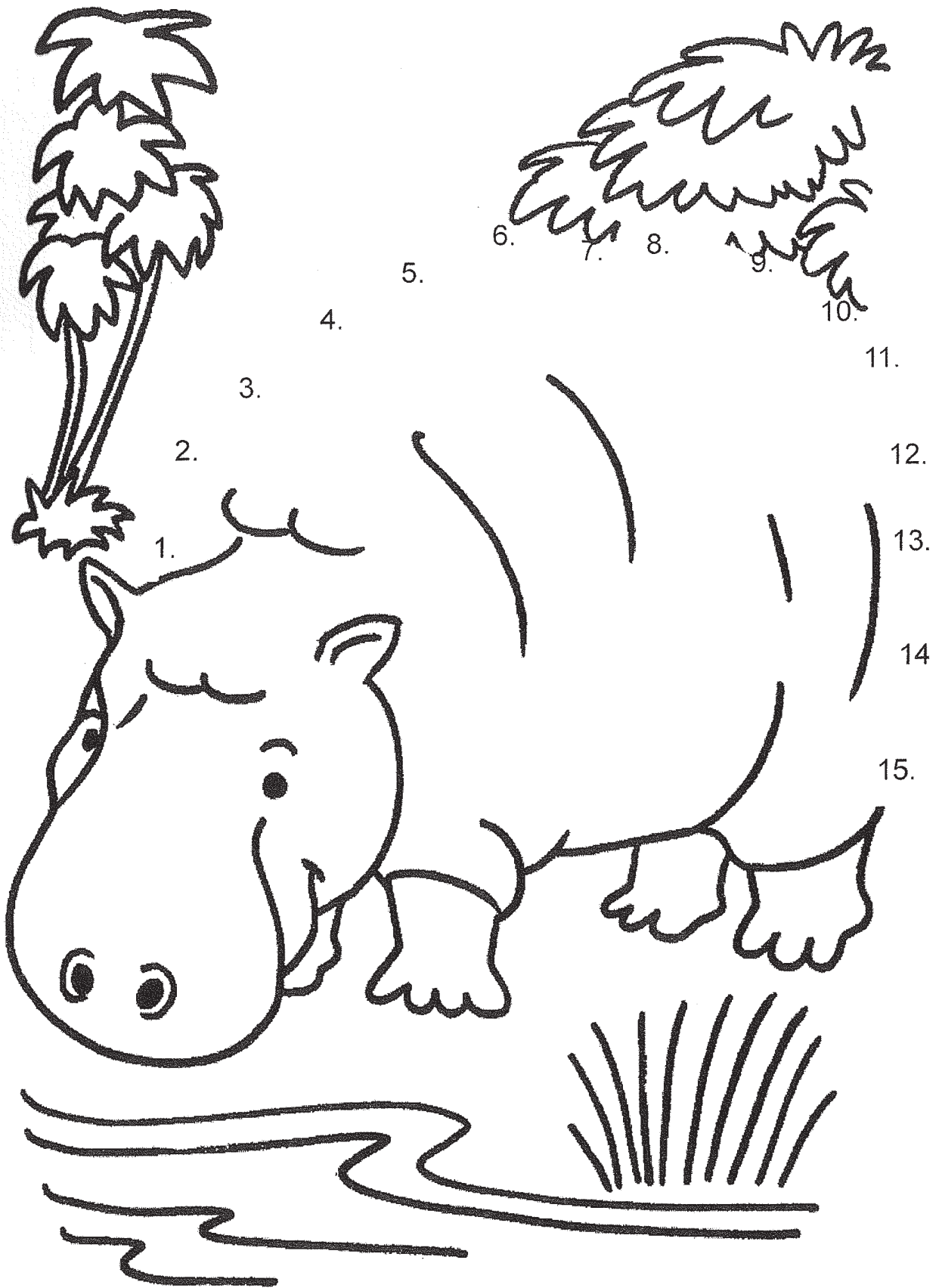

Kösd össze a pontokat 15-ig! Színezd ki a rajzot!



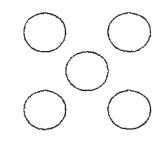
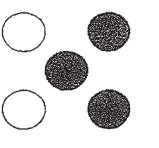

# Összeadás 16-ig

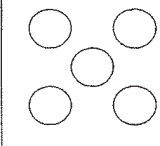
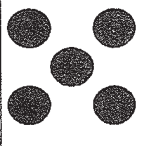
1. Old meg a műveletet!

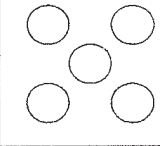
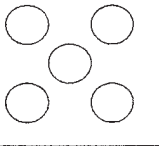
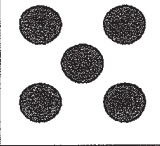

				<input type="text"/>	+	<input type="text"/>	=	<input type="text"/>
---	---	---	--	----------------------	---	----------------------	---	----------------------

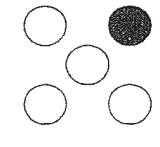
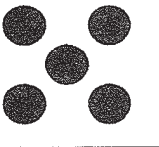
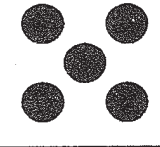
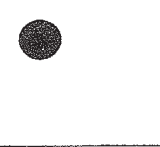

				<input type="text"/>	+	<input type="text"/>	=	<input type="text"/>
---	---	---	--	----------------------	---	----------------------	---	----------------------

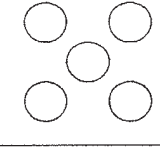
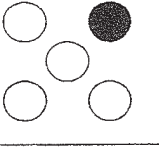
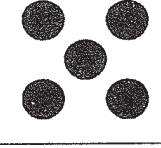
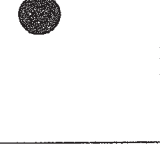

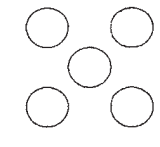
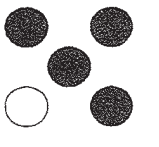
				<input type="text"/>	+	<input type="text"/>	=	<input type="text"/>
---	---	---	--	----------------------	---	----------------------	---	----------------------

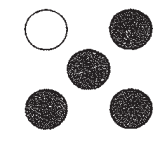
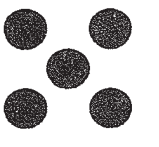

				<input type="text"/>	+	<input type="text"/>	=	<input type="text"/>
--	--	--	---	----------------------	---	----------------------	---	----------------------

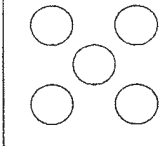
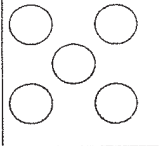
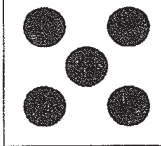

				<input type="text"/>	+	<input type="text"/>	=	<input type="text"/>
---	---	---	--	----------------------	---	----------------------	---	----------------------

				<input type="text"/>	+	<input type="text"/>	=	<input type="text"/>
---	---	---	--	----------------------	---	----------------------	---	----------------------

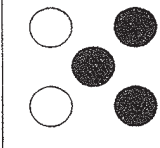
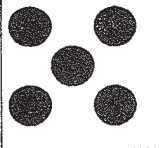
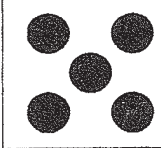
				<input type="text"/>	+	<input type="text"/>	=	<input type="text"/>
---	---	---	--	----------------------	---	----------------------	---	----------------------

				<input type="text"/>	+	<input type="text"/>	=	<input type="text"/>
---	---	---	--	----------------------	---	----------------------	---	----------------------

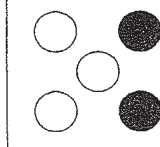
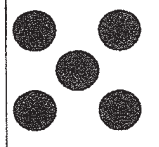
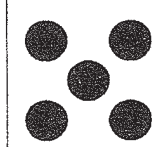
				<input type="text"/>	+	<input type="text"/>	=	<input type="text"/>
---	---	---	--	----------------------	---	----------------------	---	----------------------

				<input type="text"/>	+	<input type="text"/>	=	<input type="text"/>
---	---	---	--	----------------------	---	----------------------	---	----------------------



# Kivonás 16-ig

1. Old meg a műveletet!

				$16 - \square = \square$
--	--	--	--	--------------------------

				$\square - \square = \square$
--	--	--	--	-------------------------------

				$\square - \square = \square$
--	--	--	--	-------------------------------

				$\square - \square = \square$
--	--	--	--	-------------------------------

				$\square - \square = \square$
--	--	--	--	-------------------------------

				$\square - \square = \square$
--	--	--	--	-------------------------------

				$\square - \square = \square$
--	--	--	--	-------------------------------

				$\square - \square = \square$
--	--	--	--	-------------------------------

				$\square - \square = \square$
--	--	--	--	-------------------------------

				$\square - \square = \square$
--	--	--	--	-------------------------------

## Műveletek gyakorlása 16-ig

1. Matyinak 2 tehene van. Az egyik 7 liter, a másik 9 liter tejet ad. Összesen hány liter tejet ad?



2. Hasonlítsd össze a számokat! ( $>$ ,  $<$ ,  $=$ )

$12 \square 11$	$13 \square 11$	$13 \square 13$	$14 \square 11$
$15 \square 14$	$11 \square 13$	$16 \square 14$	$12 \square 15$
$12 \square 16$	$15 \square 16$	$12 \square 15$	$11 \square 10$

3. Számold ki!

$10+6=$	$7+7=$	$11+2=$	$13+3=$
$9+7=$	$7+9=$	$10+4=$	$12+3=$
$9+6=$	$6+8=$	$9+3=$	$7+8=$
$8+7=$	$11+1=$	$11+4=$	$5+5=$

4. a) Írd be a megfelelő  $<$ ,  $>$ ,  $=$  jelet!

$10+2 \square 12$	$14+2 \square 13$	$11 \square 13+2$
$7+5 \square 12$	$6+6 \square 11$	$15 \square 9+5$
$13+3 \square 16$	$11+3 \square 15$	$16 \square 14+2$

b)

$12-6 \square 9$	$15-9 \square 3$	$14-3 \square 11$
$12-7 \square 5$	$15-8 \square 7$	$11-5 \square 4$
$14-7 \square 6$	$15-6 \square 8$	$11-2 \square 8$

# Összeadás 17-ig

más  
dnak



1. Old meg a műveletet!

			$10 + \square = \square$
			$\square + \square = \square$
			$\square + \square = \square$
			$\square + \square = \square$
			$\square + \square = \square$
			$\square + \square = \square$
			$\square + \square = \square$
			$\square + \square = \square$
			$\square + \square = \square$
			$\square + \square = \square$

# Kivonás 17-ig

1. Old meg a műveletet!

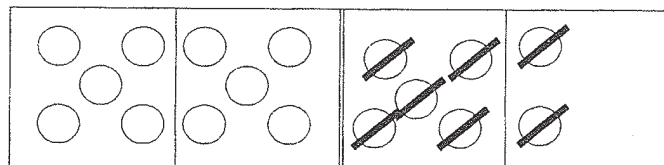

17

$$- \square = \square$$

$$= \square$$

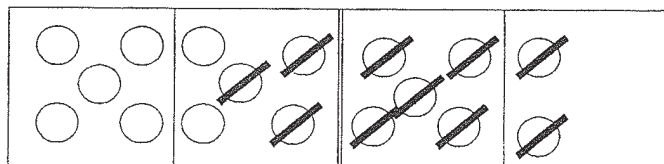

$$\square - \square = \square$$

$$= \square$$

$$= \square$$

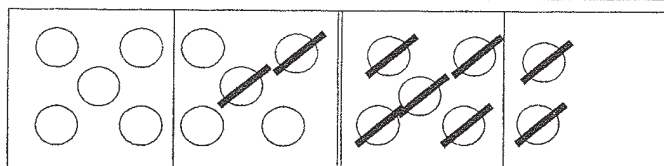

$$\square - \square = \square$$

$$= \square$$

$$= \square$$

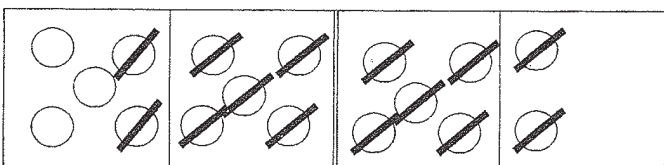

$$\square - \square = \square$$

$$= \square$$

$$= \square$$

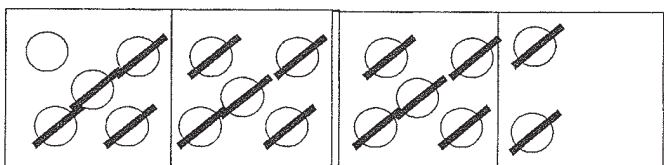

$$\square - \square = \square$$

$$= \square$$

$$= \square$$

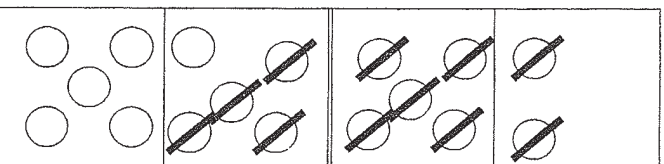

$$\square - \square = \square$$

$$= \square$$

$$= \square$$

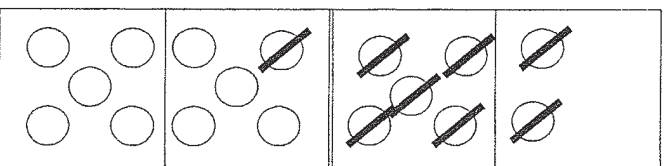

$$\square - \square = \square$$

$$= \square$$

$$= \square$$

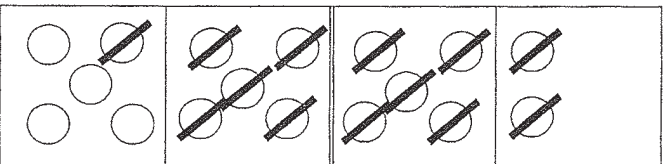

$$\square - \square = \square$$

$$= \square$$

$$= \square$$

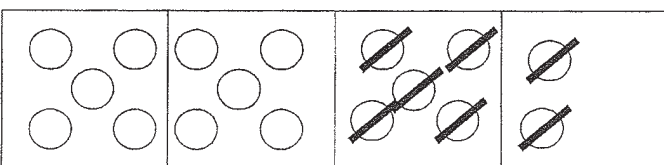

$$\square - \square = \square$$

$$= \square$$

$$= \square$$

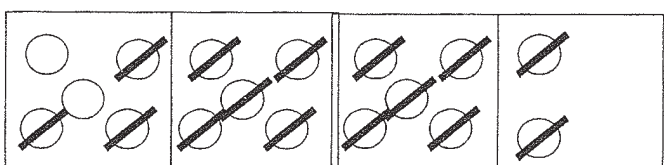

$$\square - \square = \square$$

$$= \square$$

$$= \square$$

## Műveletek gyakorlása 17-ig

1. Micimackónak születésnapja volt. Meghívta barátait egy kis ünneplésre. A vendégek ajándékot hoztak neki. Tigris 6, Malacka 4, Füles pedig 7 üveg mézet hozott. Összesen hány üveggel kapott az ünnepelt?



2. Végezd el a kivonásokat!

$17-8=$

$14-8=$

$14-5=$

$17-7-1=$

$14-4-4=$

$14-4-1=$

$17-9=$

$16-9=$

$15-9=$

$17-7-2=$

$16-6-\square=$

$15-6-\square=$

$16-8=$

$15-6=$

$13-9=$

$16-\square-\square=$

$15-\square-\square=$

$13-\square-\square=$

$15-8=$

$15-7=$

$14-7=$

$15-\square-\square=$

$15-\square-\square=$

$14-\square-\square=$

$16-7=$

$14-6=$

$14-9=$

$16-\square-\square=$

$14-\square-\square=$

$14-\square-\square=$

3. Írd be a megfelelő  $<$ ,  $>$ ,  $=$  jelet!

$15+2 \square 12$

$14+2 \square 17$

$17 \square 14+2$

$7+7 \square 16$

$9+6 \square 15$

$16 \square 9+8$

$14+3 \square 17$

$12+3 \square 13$

$15 \square 12+2$

# Összeadás 18-ig

1. Old meg a műveletet!

				10	+	<input type="text"/>	=	<input type="text"/>
--	--	--	--	----	---	----------------------	---	----------------------

				<input type="text"/>	+	<input type="text"/>	=	<input type="text"/>
--	--	--	--	----------------------	---	----------------------	---	----------------------

				<input type="text"/>	+	<input type="text"/>	=	<input type="text"/>
--	--	--	--	----------------------	---	----------------------	---	----------------------

				<input type="text"/>	+	<input type="text"/>	=	<input type="text"/>
--	--	--	--	----------------------	---	----------------------	---	----------------------

				<input type="text"/>	+	<input type="text"/>	=	<input type="text"/>
--	--	--	--	----------------------	---	----------------------	---	----------------------

				<input type="text"/>	+	<input type="text"/>	=	<input type="text"/>
--	--	--	--	----------------------	---	----------------------	---	----------------------

				<input type="text"/>	+	<input type="text"/>	=	<input type="text"/>
--	--	--	--	----------------------	---	----------------------	---	----------------------

				<input type="text"/>	+	<input type="text"/>	=	<input type="text"/>
--	--	--	--	----------------------	---	----------------------	---	----------------------

				<input type="text"/>	+	<input type="text"/>	=	<input type="text"/>
--	--	--	--	----------------------	---	----------------------	---	----------------------

				<input type="text"/>	+	<input type="text"/>	=	<input type="text"/>
--	--	--	--	----------------------	---	----------------------	---	----------------------

# Kivonás 18-ig

1. Old meg a műveletet!

				$18 - \square = \square$
--	--	--	--	--------------------------

				$\square - \square = \square$
--	--	--	--	-------------------------------

				$\square - \square = \square$
--	--	--	--	-------------------------------

				$\square - \square = \square$
--	--	--	--	-------------------------------

				$\square - \square = \square$
--	--	--	--	-------------------------------

				$\square - \square = \square$
--	--	--	--	-------------------------------

				$\square - \square = \square$
--	--	--	--	-------------------------------

				$\square - \square = \square$
--	--	--	--	-------------------------------

				$\square - \square = \square$
--	--	--	--	-------------------------------

				$\square - \square = \square$
--	--	--	--	-------------------------------





# Összeadás 19-ig

1. Old meg a műveletet!

				10	+	<input type="text"/>	=	<input type="text"/>
--	--	--	--	----	---	----------------------	---	----------------------

				<input type="text"/>	+	<input type="text"/>	=	<input type="text"/>
--	--	--	--	----------------------	---	----------------------	---	----------------------

				<input type="text"/>	+	<input type="text"/>	=	<input type="text"/>
--	--	--	--	----------------------	---	----------------------	---	----------------------

				<input type="text"/>	+	<input type="text"/>	=	<input type="text"/>
--	--	--	--	----------------------	---	----------------------	---	----------------------

				<input type="text"/>	+	<input type="text"/>	=	<input type="text"/>
--	--	--	--	----------------------	---	----------------------	---	----------------------

				<input type="text"/>	+	<input type="text"/>	=	<input type="text"/>
--	--	--	--	----------------------	---	----------------------	---	----------------------

				<input type="text"/>	+	<input type="text"/>	=	<input type="text"/>
--	--	--	--	----------------------	---	----------------------	---	----------------------

				<input type="text"/>	+	<input type="text"/>	=	<input type="text"/>
--	--	--	--	----------------------	---	----------------------	---	----------------------

				<input type="text"/>	+	<input type="text"/>	=	<input type="text"/>
--	--	--	--	----------------------	---	----------------------	---	----------------------

				<input type="text"/>	+	<input type="text"/>	=	<input type="text"/>
--	--	--	--	----------------------	---	----------------------	---	----------------------

# Kivonás 19-ig

1. Old meg a műveletet!

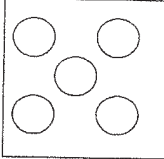
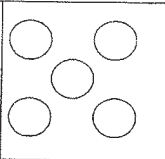
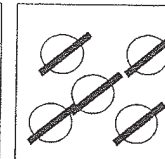
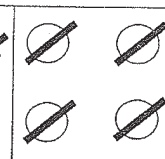
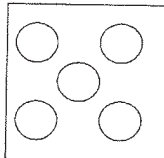
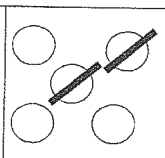
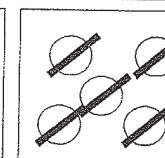
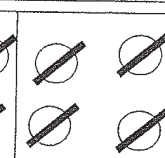
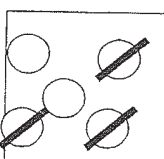
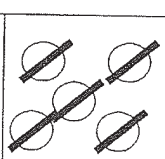
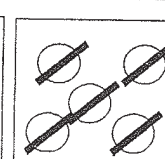
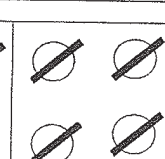
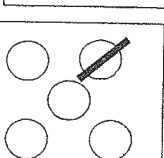
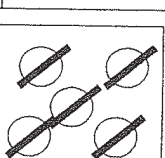
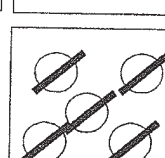
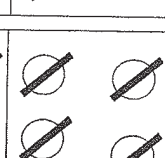
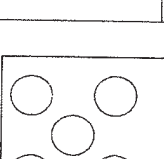
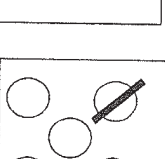
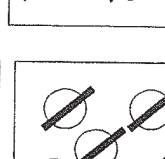
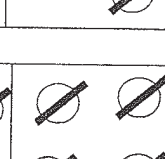
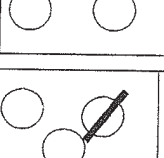
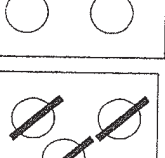
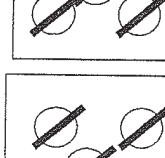
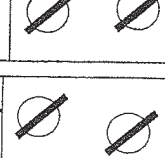
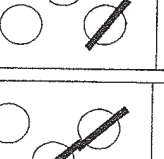
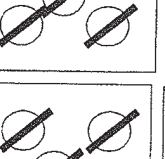
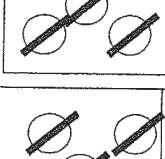
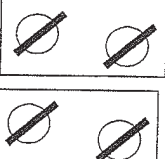
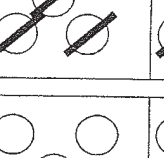
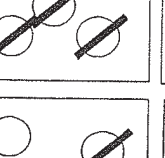
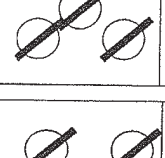
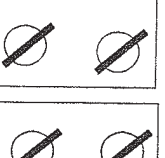
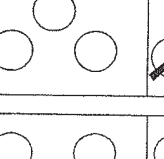
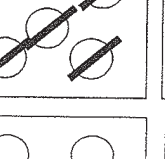
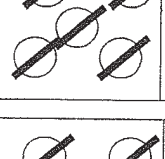
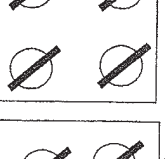
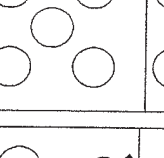
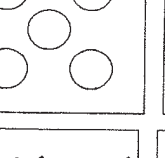
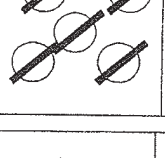
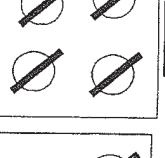
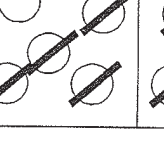
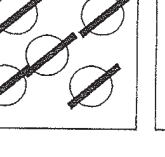
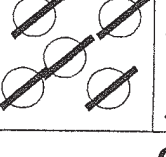
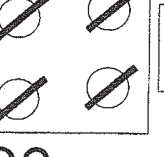
				19	-	<input type="text"/>	=	<input type="text"/>
				<input type="text"/>	-	<input type="text"/>	=	<input type="text"/>
				<input type="text"/>	-	<input type="text"/>	=	<input type="text"/>
				<input type="text"/>	-	<input type="text"/>	=	<input type="text"/>
				<input type="text"/>	-	<input type="text"/>	=	<input type="text"/>
				<input type="text"/>	-	<input type="text"/>	=	<input type="text"/>
				<input type="text"/>	-	<input type="text"/>	=	<input type="text"/>
				<input type="text"/>	-	<input type="text"/>	=	<input type="text"/>
				<input type="text"/>	-	<input type="text"/>	=	<input type="text"/>
				<input type="text"/>	-	<input type="text"/>	=	<input type="text"/>
				<input type="text"/>	-	<input type="text"/>	=	<input type="text"/>

# Műveletek gyakorlása 19-ig

1. a) Végezd el az összeadásokat!

$8+2+6=$

$6+4+7=$

$11+8=$

$15+4=$

$4+6+7=$

$9+1+9=$

$11+9=$

$15+3=$

$5+5+9=$

$7+3+8=$

$12+7=$

$16+3=$

$2+8+9=$

$1+9+6=$

$12+6=$

$16+2=$

$3+7+8=$

$7+3+9=$

$13+4=$

$17+2=$

b)  $10+9=$

$12+5=$

$15+1=$

$12+ \square = 19$

$10+7=$

$12+4=$

$15+2=$

$11+ \square = 19$

$10+8=$

$13+3=$

$15+0=$

$10+ \square = 19$

$10+6=$

$12+2=$

$16+1=$

$16+ \square = 19$

$10+5=$

$14+2=$

$16+0=$

$14+ \square = 19$

2. Végezd el a kivonásokat!

$19-9-4=$

$19-6=$

$19- \square = 2$

$19- \square = 12$

$19-9-6=$

$19-4=$

$19- \square = 3$

$19- \square = 13$

$19-9-5=$

$19-3=$

$19- \square = 5$

$19- \square = 15$

$19-9-0=$

$19-5=$

$19- \square = 7$

$19- \square = 17$

$19-9-8=$

$19-8=$

$19- \square = 6$

$19- \square = 16$

$19-9-2=$

$19-1=$

$19- \square = 4$

$19- \square = 14$

$19-9-7=$

$19-7=$

$19- \square = 1$

$19- \square = 11$

3. Számold ki!

$5+5+2=$

$6+4+7=$

$19-5=$

$18-2=$

$6+4+6=$

$3+5+2=$

$19-8=$

$18-5=$

$7+3+8=$

$1+9+9=$

$19-3=$

$17-2=$

$2+8+7=$

$5+5+3=$

$19-7=$

$17-7=$

## Feladatok 19-ig

1. Elef Anti egyik nap 10 kilogramm, másik nap pedig 9 kilogramm banánt evett meg. Összesen hány kilogramm banánt fogyasztott el?

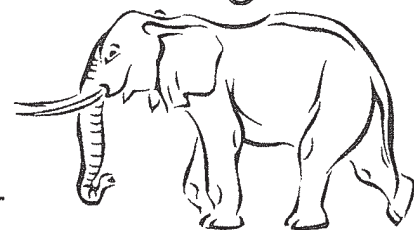

2. Hasonlítsd össze a számokat!  
Írd be a  $<$ ,  $>$ ,  $=$  jelet!

$16 \square 17$	$13 \square 12$	$17 \square 14$	$11 \square 17$
$17 \square 18$	$18 \square 13$	$19 \square 18$	$14 \square 15$
$19 \square 19$	$15 \square 19$	$12 \square 15$	$19 \square 17$

3. Írd be a megfelelő  $<$ ,  $>$ ,  $=$  jelet!

a)  $15+2 \square 12$      $14+3 \square 19$      $19 \square 13+2$   
 $17+1 \square 19$      $16+2 \square 18$      $14 \square 9+5$   
 $12+3 \square 15$      $18+1 \square 15$      $16 \square 17+2$

b)

$16-6 \square 9$	$15-8 \square 13$	$19-3 \square 16$
$18-7 \square 10$	$19-8 \square 12$	$14-5 \square 12$
$19-7 \square 13$	$17-6 \square 18$	$19-2 \square 15$

4. Számítsd ki!

$10+6=$	$7+7=$	$11+2=$	$13+3=$
$9+7=$	$7+9=$	$10+4=$	$12+3=$
$9+6=$	$6+8=$	$9+3=$	$7+8=$
$8+7=$	$11+1=$	$11+4=$	$5+5=$

Vezesd át a kis barátokat a labirintuson a kacsáig!

ap  
zese

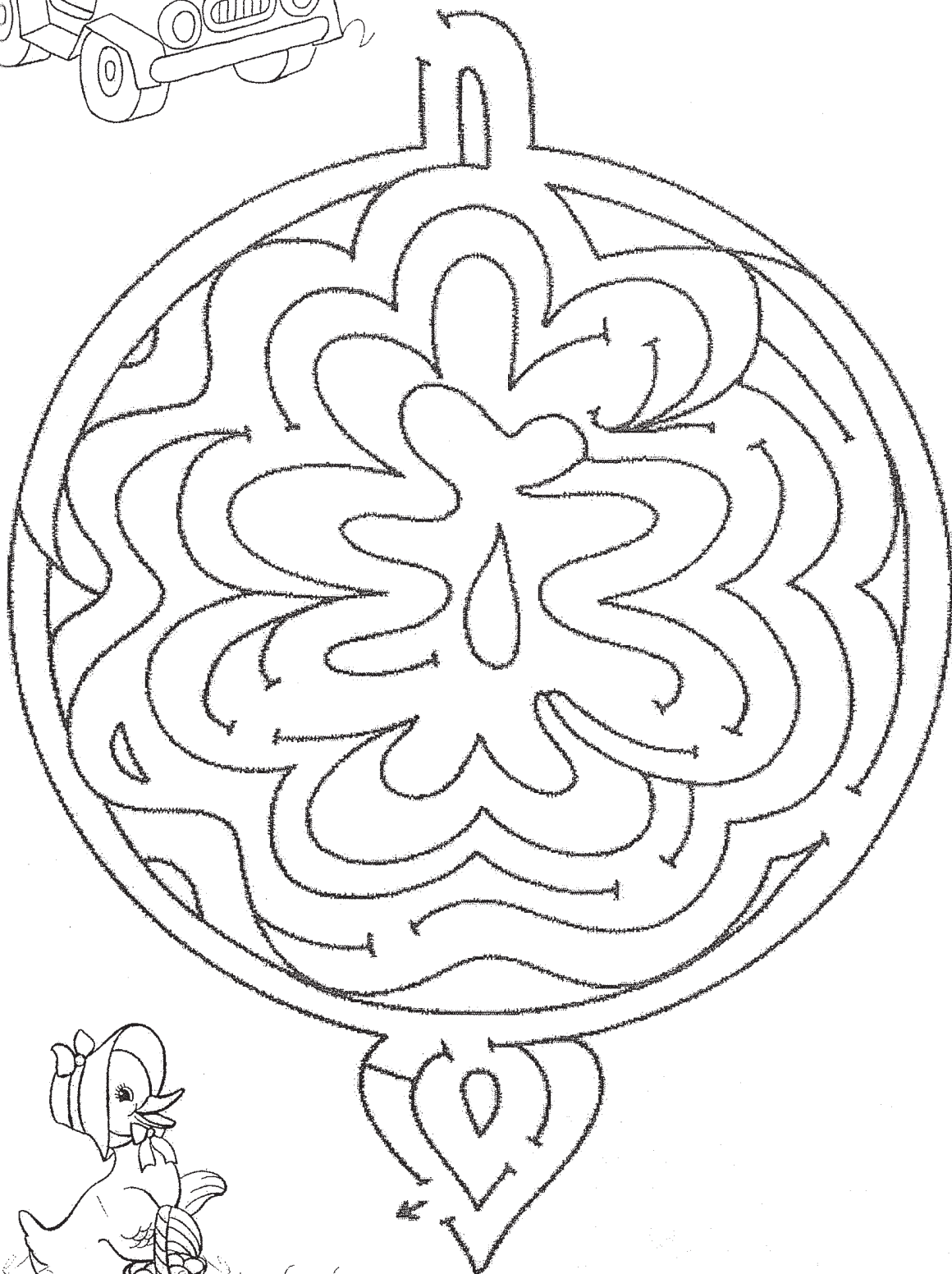

# Összeadás 20-ig

1. Old meg a műveletet!

				$20 + \square = \square$
--	--	--	--	--------------------------

				$\square + \square = \square$
--	--	--	--	-------------------------------

				$\square + \square = \square$
--	--	--	--	-------------------------------

				$\square + \square = \square$
--	--	--	--	-------------------------------

				$\square + \square = \square$
--	--	--	--	-------------------------------

				$\square + \square = \square$
--	--	--	--	-------------------------------

				$\square + \square = \square$
--	--	--	--	-------------------------------

				$\square + \square = \square$
--	--	--	--	-------------------------------

				$\square + \square = \square$
--	--	--	--	-------------------------------

				$\square + \square = \square$
--	--	--	--	-------------------------------

# Kivonás 20-ig

1. Old meg a műveletet!

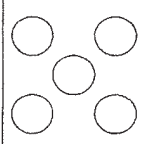
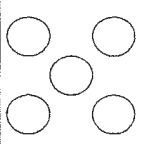
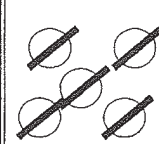
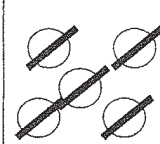
				20	-	<input type="text"/>	=	<input type="text"/>
---	---	---	---	----	---	----------------------	---	----------------------

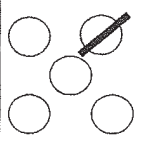
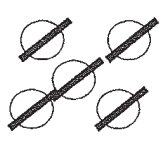
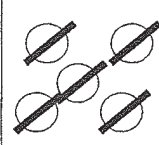
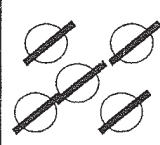
				<input type="text"/>	-	<input type="text"/>	=	<input type="text"/>
---	---	---	---	----------------------	---	----------------------	---	----------------------

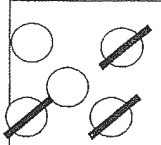
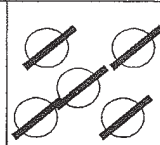
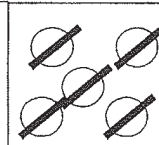
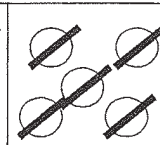
				<input type="text"/>	-	<input type="text"/>	=	<input type="text"/>
---	---	---	---	----------------------	---	----------------------	---	----------------------

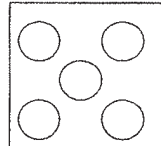
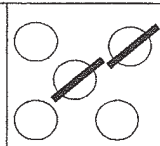
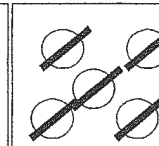
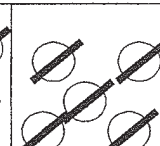
				<input type="text"/>	-	<input type="text"/>	=	<input type="text"/>
--	--	--	--	----------------------	---	----------------------	---	----------------------

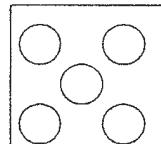
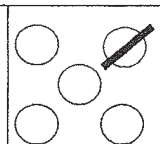
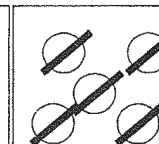
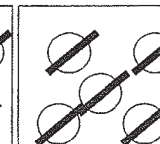
				<input type="text"/>	-	<input type="text"/>	=	<input type="text"/>
---	---	---	---	----------------------	---	----------------------	---	----------------------

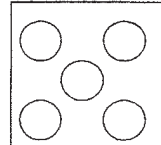
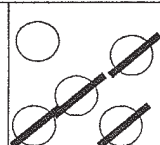
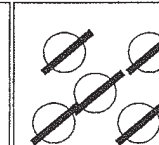
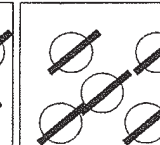
				<input type="text"/>	-	<input type="text"/>	=	<input type="text"/>
---	---	---	---	----------------------	---	----------------------	---	----------------------

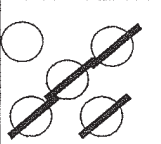
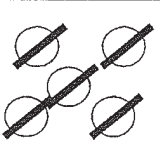
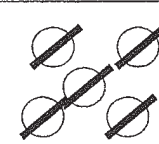
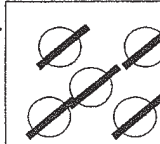
				<input type="text"/>	-	<input type="text"/>	=	<input type="text"/>
---	---	---	---	----------------------	---	----------------------	---	----------------------

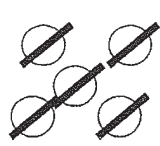
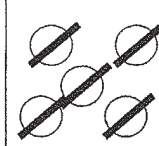
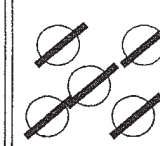
				<input type="text"/>	-	<input type="text"/>	=	<input type="text"/>
---	---	---	---	----------------------	---	----------------------	---	----------------------

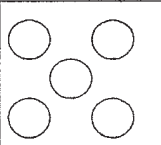
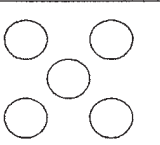
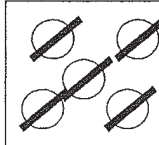
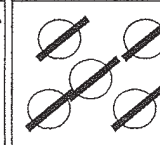
				<input type="text"/>	-	<input type="text"/>	=	<input type="text"/>
---	---	---	---	----------------------	---	----------------------	---	----------------------

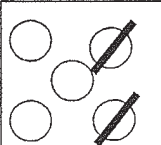
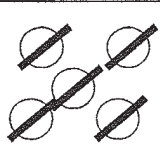
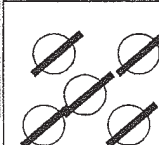
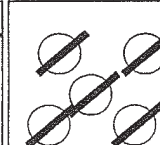
				<input type="text"/>	-	<input type="text"/>	=	<input type="text"/>
---	---	---	---	----------------------	---	----------------------	---	----------------------

## Összeadás és kivonás 0-val

1. Anya a piacon 12 tojást vett. Vacsorára 8-  
reggelire pedig 4-et sütött meg. Mennyi  
tojás maradt? \_\_\_\_\_

2. Bálintnak 5 papagája volt. Reggel, amikor  
megetette őket, elfelejtette bezárni a kalitkát.  
A szép színes madarak mind kirepültek.  
Mennyi maradt a kalitkában? \_\_\_\_\_

3. a) Számold ki!

$15-5-10=$

$14-4-10=$

$11-1-10=$

$12-2-10=$

$17-7-10=$

$19-9-10=$

$16-6-10=$

$13-3-10=$

$18-8-10=$

b)  $5+0=$

$16+0=$

$0-15=$

$16-0=$

$0+1=$

$0+3=$

$0-20=$

$12-0=$

$9+0=$

$7+0=$

$10-0=$

$0-5=$

4. Pótold a számokat!

$3+\square=3$

$\square+2=2$

$12-\square=12$

$8+\square=8$

$\square+9=9$

$14-\square=14$

$7+\square=7$

$\square+6=6$

$20-\square=20$

$16-\square=0$

$12-\square=0$

$17-\square=0$

$8-\square=0$

$10-\square=0$

$15-\square=0$



# Írd a hiányzó számokat a körökbe!

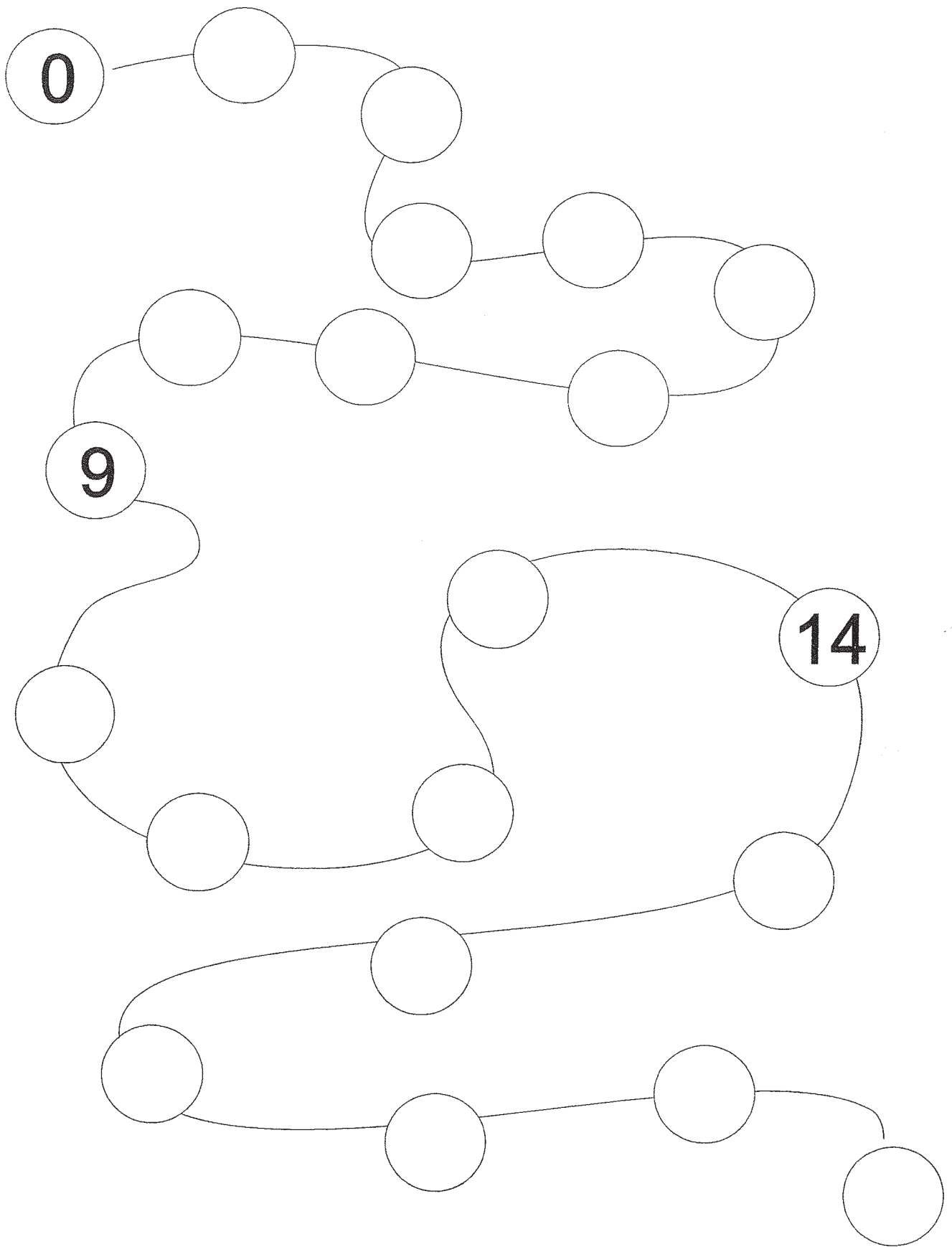

# Számok összehasonlítása a 20-as számkörben

1. Írd a számok közé a megfelelő <, >, = jelet

10		11	10		14	19		17	10		20
11		13	13		15	20		18	14		17
12		11	12		14	17		15	6		16
14		10	15		13	18		20	14		7
12		12	17		18	19		19	15		5
10		15	15		16	16		19	20		10
9		11	18		9	10		13	12		12

8		18	17		7	20		10
7		14	19		6	18		8
12		9	16		9	5		15
15		15	4		14	2		12

2. Írd be a hiányzó számokat!

12		14			19		16		17		
16		18			14						
		19	20			13		17			
15		17			11				15		

18		20	16		17		20	16				12
15		18	12				16	12		11		8
12		14	10		12		14	18		16		14
10		12	15				19	15				12

## Feladatok a 20-as számkörben

1. a)  $15+2=$        $14+2=$        $16+2=$   
 $12+5=$        $16+4=$        $18+1=$   
 $13+6=$        $11+8=$        $13+7=$   
 $19+1=$        $10+7=$        $15+3=$

b)  $16-6=$        $16-4=$        $20-12=$   
 $17-5=$        $17-4=$        $20-17=$   
 $19-3=$        $20-6=$        $16-14=$   
 $14-2=$        $20-3=$        $15-11=$

2. a) Írd be a megfelelő  $<$ ,  $>$ ,  $=$  jelet!

$19+1 \square 20$        $14+2 \square 17$        $12+2 \square 14$   
 $17+3 \square 18$        $13+6 \square 19$        $17+5 \square 15$   
 $8+11 \square 16$        $15+3 \square 20$        $11+2 \square 13$   
 $6+12 \square 18$        $12+5 \square 16$        $7+9 \square 17$

b)  $18-6 \square 12$        $18-9 \square 3$        $14-3 \square 11$   
 $19-7 \square 5$        $12-8 \square 7$        $11-5 \square 4$   
 $13-7 \square 6$        $16-6 \square 8$        $12-2 \square 8$   
 $19-6 \square 12$        $11-1 \square 9$        $19-6 \square 13$

c)  $18-16 \square 2$        $20-15 \square 3$        $14 \square 12-10$   
 $19-17 \square 4$        $16-14 \square 7$        $11 \square 17-16$   
 $15-14 \square 8$        $12-10 \square 2$        $12 \square 20-8$

## Feladatok

1. A kis juhászbojtár a legelőre terelte gazdájának mind a 20 birkáját. A nyájban 9 fekete birka van. Hány fehér birka van a nyájban?

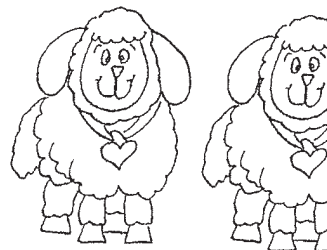

2. A futóversenyen 6 lány és 4-gyel több fiú futott.

Hányan voltak a fiúk?

Hányan futottak összesen? \_\_\_\_\_

3. Húzd át a 16-tól kisebb számokat!

17 8 11 19 12 6 15 18

20 4 13 6 7 10 16 5

4. Húzd át a 12-nél nagyobb számokat!

9 12 3 16 17 11 1 19

10 18 20 6 14 12 4 13

## Az idő mérése

Rajzold le az órát és a mutatóit!  
Színezd a nagymutatót kékre,  
a kismutatót pirosra.

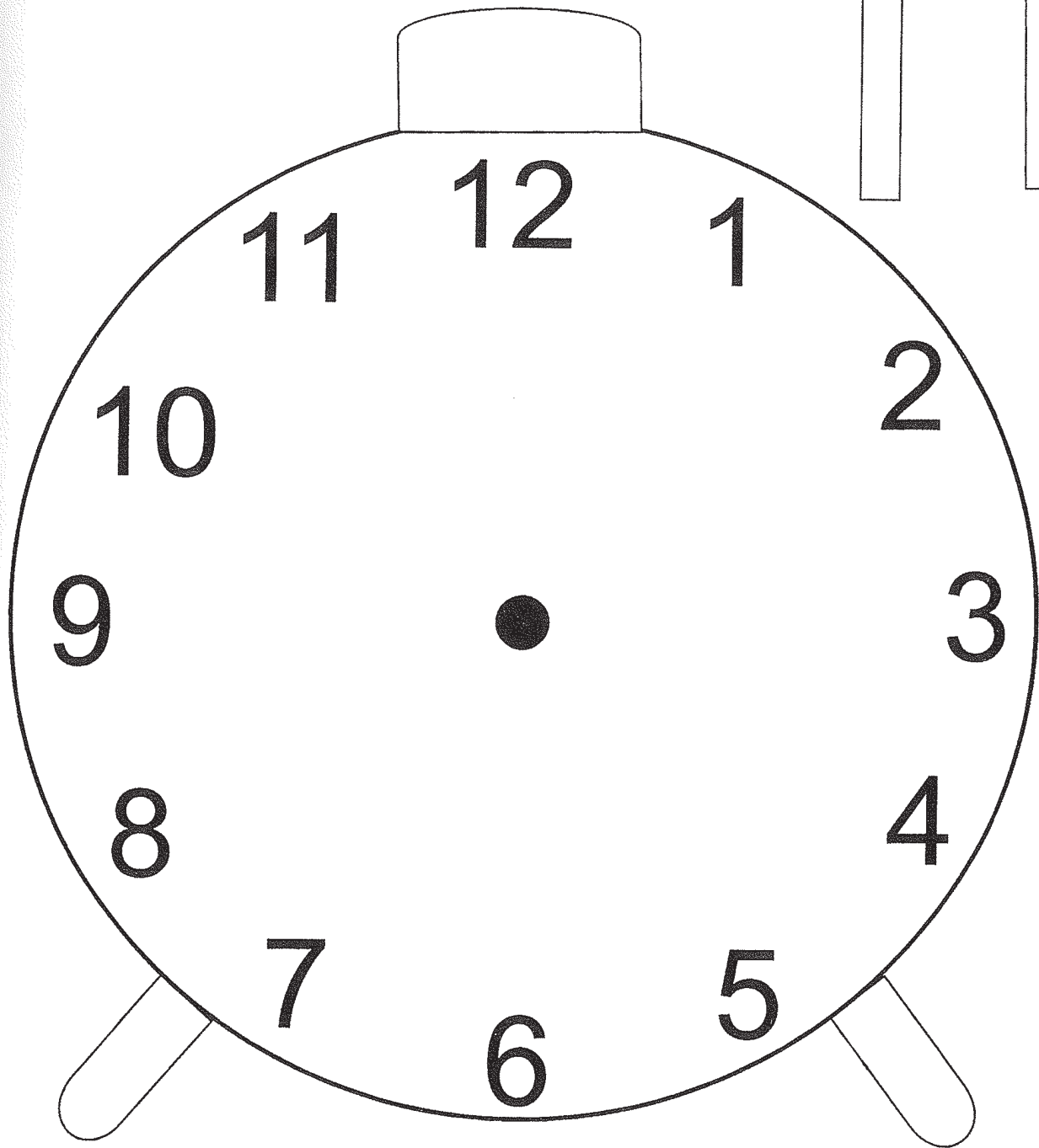

# Feladatok az idő mérésére

1. Jelöld be az időt, hogy mit, mikor teszel!

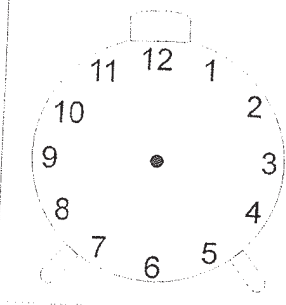

Reggel  
felkelek

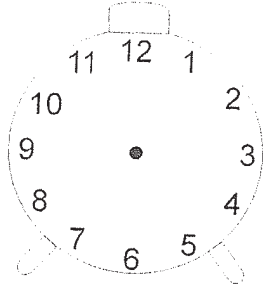

Indulok az  
iskolába

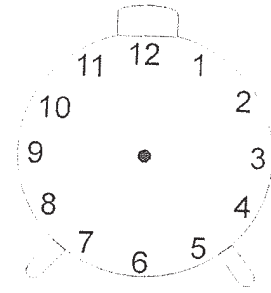

Kezdődik  
a tanítás

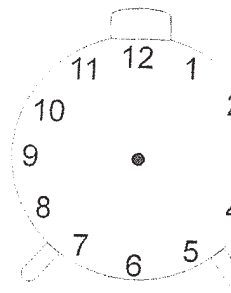

Uzsonna  
szünet

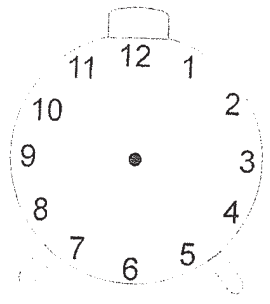

Vége a  
tanításnak

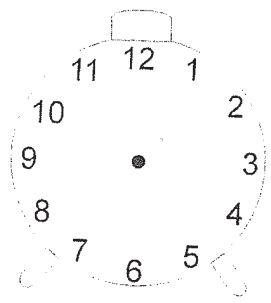

Hazaérek

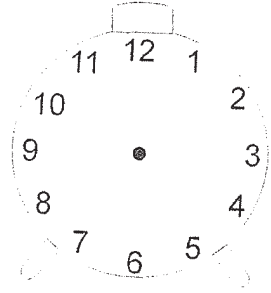

Játszani  
kezdek

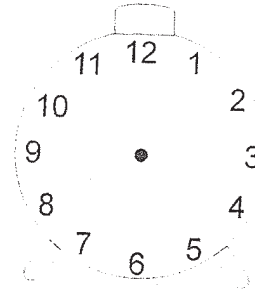

Esti  
lefekvés

2. Mennyi időt mutatnak az órák?

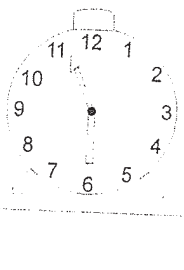
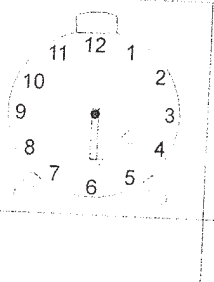
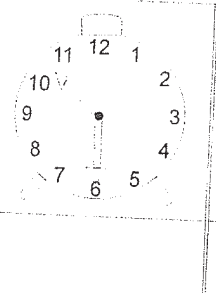
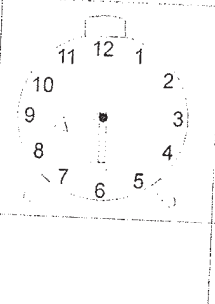
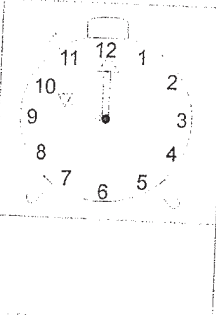
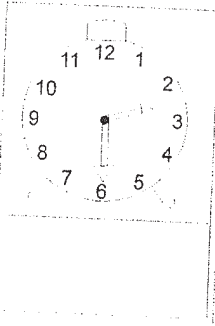
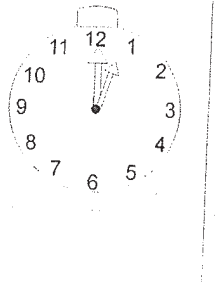
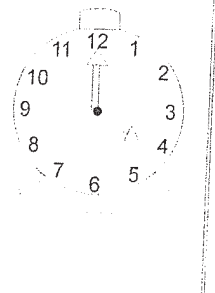
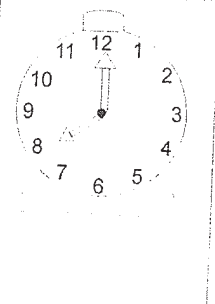
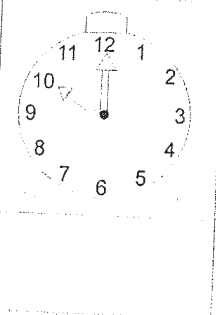
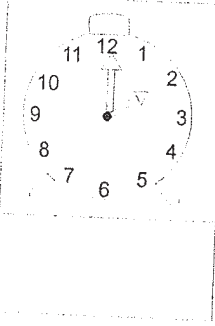

## A 20-as számkör gyakorlása

1.a) Írd le az egyjegyű számokat  
növekvő sorrendben!

0

b) Írd le csökkenő sorrendben!

9

c) Írd le a kétjegyű számokat  
növekvő sorrendben!

10

d) Írd le csökkenő sorrendben!

20

2. Melyik az a szám, amely:

- 14-től kisebb, a 12-től pedig nagyobb? \_\_\_\_\_
- 17-től nagyobb, a 19-től pedig kisebb? \_\_\_\_\_
- a 9-től nagyobb, a 11-től pedig kisebb? \_\_\_\_\_
- a 16-tól kisebb, a 14-től pedig nagyobb? \_\_\_\_\_

3. a) Következő számokat írd le szavakkal!

6 _____	14 _____	11 _____
18 _____	19 _____	13 _____
12 _____	20 _____	10 _____
17 _____	15 _____	16 _____

b) Olvasd el és írd le számjegyekkel!

tizenöt \_\_\_\_\_ tizenkettő \_\_\_\_\_ tizenegy \_\_\_\_\_  
tizenhét \_\_\_\_\_ tizennyolc \_\_\_\_\_ húsz \_\_\_\_\_

## A 20-as számkör gyakorlása

1. Kösd össze az összetartozókat!

tizenöt  
tizenhét  
tizenkettő  
tizennyolc  
hét

12  
18  
15  
7  
17

húsz  
nyolc  
tizennyolc  
tizenhat  
tizenegy

11  
16  
8  
20  
18

2. Mely szám hiányzik? Pótold a számegyenesen!

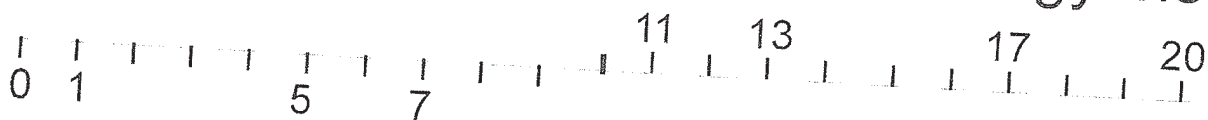

3. a) Növeld 1-gyel az alsó számokat!

10	13	16	17	19	15	11
11						

b) Csökkentsd 1-gyel az alsó számokat!

18	16	14	13	11	10	20
17						

4. Számolj: 16-tól 20-ig!

...11-től 17-ig!

...15-től 10-ig!

...20-tól 14-ig!

...13-től 7-ig!



## Feladatok 20-ig

1. Fanni kétféle függönyt vett. Az egyik 6 méter, a másik 5 méterrel hosszabb volt. Hány méter függönyt vett Fanni? \_\_\_\_\_

2. Bandi bácsinak két malaca van. Az egyik 8, a másik 9 kilogramm. Összesen hány kilogramm a két malac?  
\_\_\_\_\_

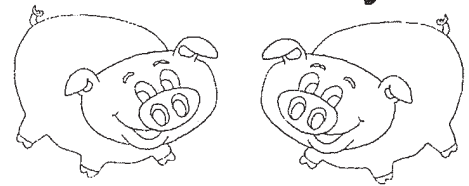

3. Csőrike tojásokat festett. 7 tojás sárga színű, 12 pedig tarka lett. Összesen hány tojást festett be?  
\_\_\_\_\_

4. Írd be a megfelelő  $<$ ,  $>$ ,  $=$  jelet!

a)  $15+3 \square 17+3$

$16+2 \square 13+5$

$16+1 \square 12+8$

$17+2 \square 12+7$

$12+5 \square 16+2$

$13+2 \square 14+3$

$11+1 \square 12+1$

$11+5 \square 10+5$

b)  $16-7 \square 14-8$

$19-6 \square 17-4$

$20-8 \square 18-16$

$19-5 \square 13-12$

$20-12 \square 16-11$

$19-13 \square 15-12$

$17-14 \square 19-11$

$13-10 \square 18-17$

# Számolj és rajzolj!

1. A két láncon összesen 17 szem gyöngy legyen!

a)

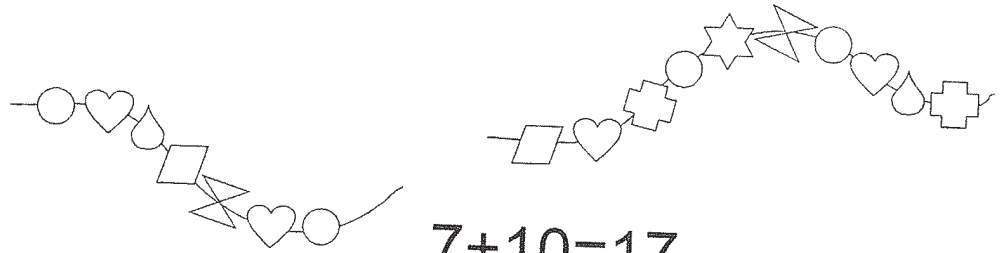

$$7 + 10 = 17$$



$$5 + \square = \square$$



$$4 + \square = \square$$

b) A két láncon összesen 20 szem gyöngy legyen!

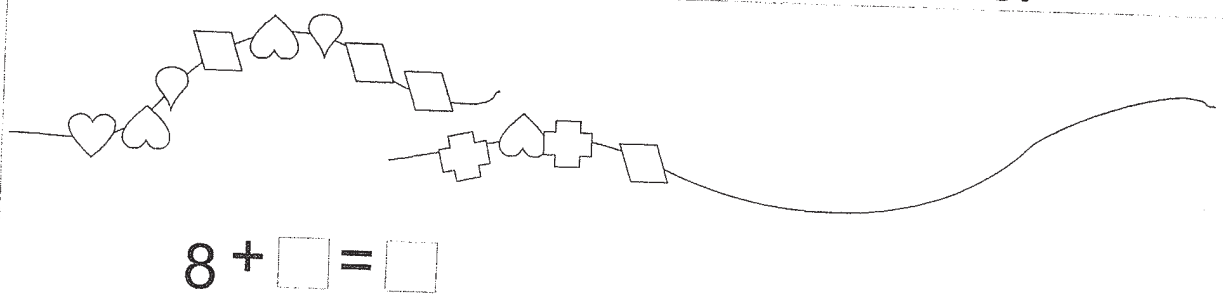

$$8 + \square = \square$$

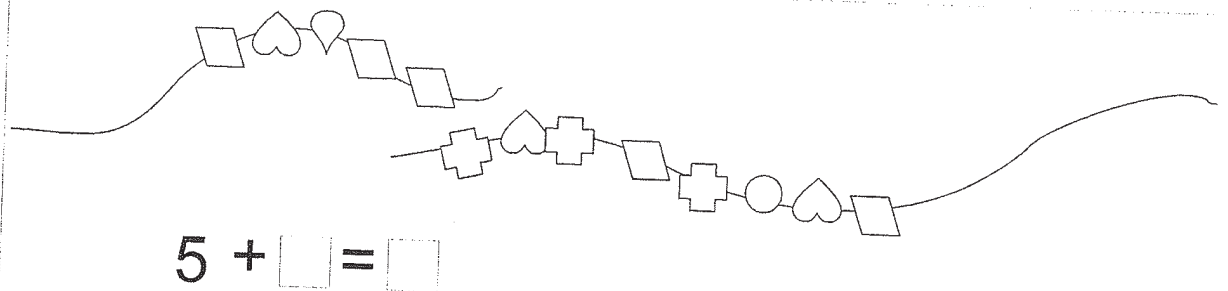

$$5 + \square = \square$$



Melyik úton jutnak el a törpék  
a bányába?

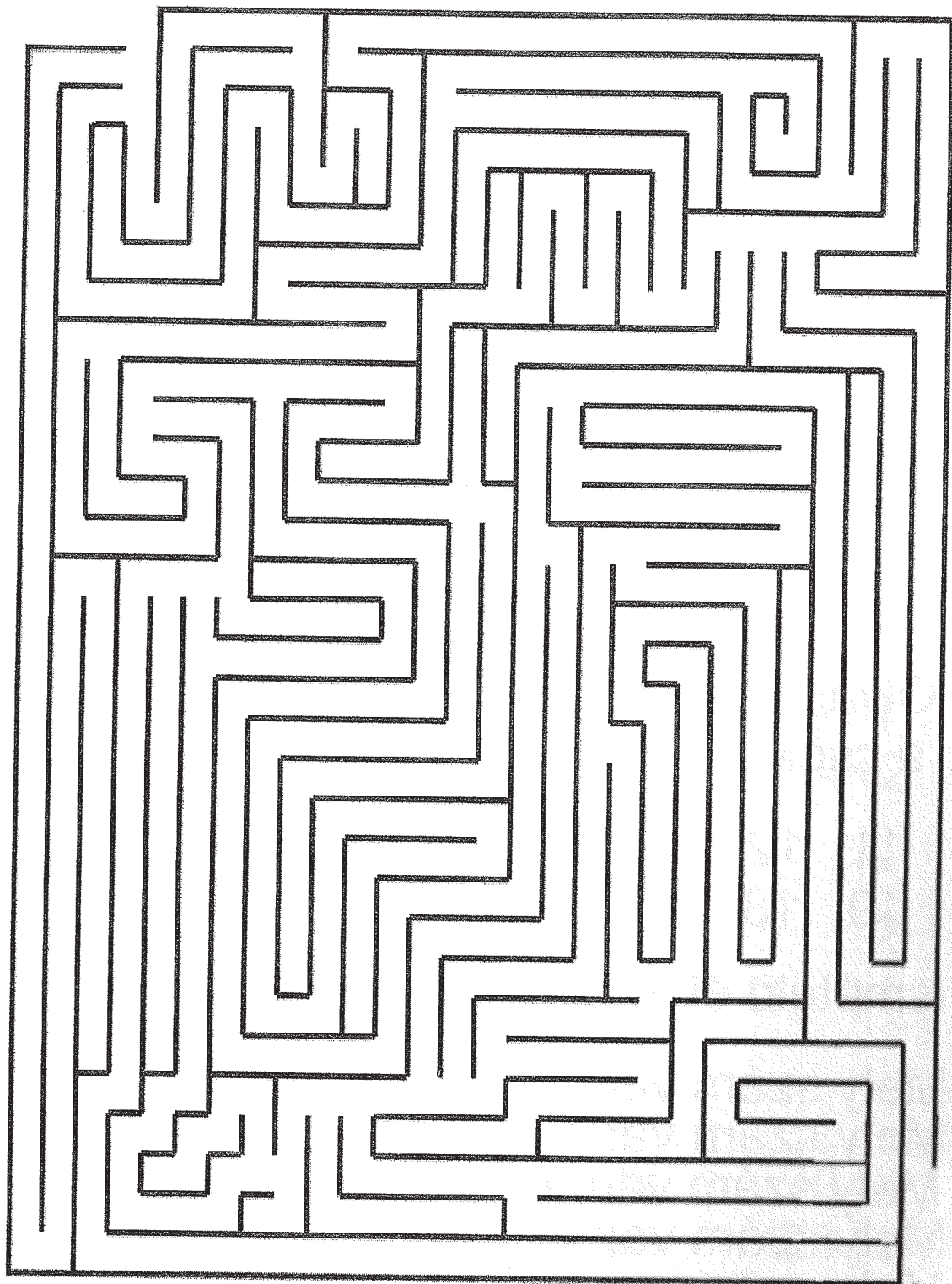

## Feladatok

1. Mely szám nagyobb 1-gyel 10-nél? \_\_\_\_\_  
 Mely szám nagyobb 1-gyel 12-nél? \_\_\_\_\_  
 Mely szám van a 20 előtt? \_\_\_\_\_  
 Mely szám van a 17 és 19 között? \_\_\_\_\_

2. Írd a számok közé a megfelelő  $<$ ,  $>$ ,  $=$  jelet!

12		14	16		18	20		11	15		16
13		16	16		14	10		19	13		16
12		12	15		15	17		20	19		15
18		15	14		17	16		12	12		14
20		10	11		10	13		14	20		11
10		19	17		19	18		13	17		17

3. a) Olvasd el először a növekvő, azután pedig a csökkenő sorrendben leírt számokat!

10	11	12	13	14	15	16	17	18	19	20
20	19	18	17	16	15	14	13	12	11	10

- b) Ismételd el fejből!

- c) Mely szám van a 12 és a 14 között? \_\_\_\_\_  
 Mely szám van a 11 és a 13 között? \_\_\_\_\_  
 Mely szám van a 15 és a 3 között? \_\_\_\_\_  
 Mely szám van a 18 és a 16 között? \_\_\_\_\_  
 Mely szám van a 20 és a 18 között? \_\_\_\_\_  
 Mely szám van a 17 és a 19 között? \_\_\_\_\_

## Feladatok 20-ig

1. Hasonlítsd össze a számokat!

Írd be a <, >, = jelet!

$20 \square 10$

$18 \square 19$

$10 \square 20$

$18 \square 17$

$19 \square 18$

$17 \square 20$

$20 \square 18$

$13 \square 15$

$17 \square 20$

$20 \square 11$

$12 \square 11$

$20 \square 16$

2. Nagymama 10 alma- és ugyanannyi barack-  
befőttet tett el télire. Összesen hány üveggel  
készített?

\_\_\_\_\_

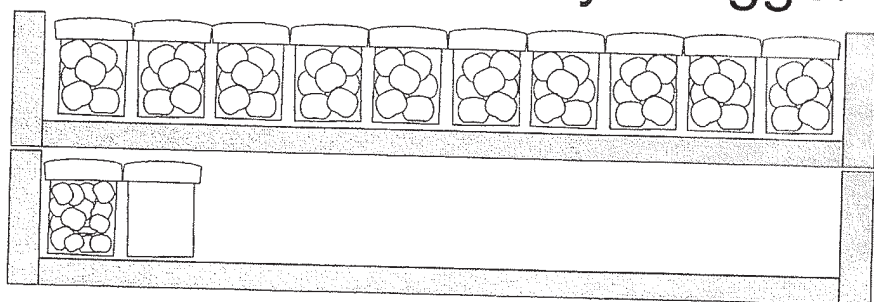

3. Írd be a megfelelő <, >, = jelet!

a)  $16+3 \square 20$

$12+3 \square 14$

$19 \square 13+7$

$17+2 \square 19$

$17+3 \square 19$

$12 \square 9+4$

$12+8 \square 17$

$13+6 \square 20$

$16 \square 14+2$

b)  $19-6 \square 7$

$20-8 \square 12$

$20-3 \square 16$

$18-7 \square 15$

$19-3 \square 17$

$16-5 \square 12$

$19-5 \square 3$

$12-6 \square 5$

$20-2 \square 14$

4. Számold ki!

$10+8=$

$12+7=$

$18-2=$

$20-3=$

$16+4=$

$7+11=$

$19-4=$

$20-6=$

$19+1=$

$3+14=$

$17-3=$

$20-8=$

$13+7=$

$11+9=$

$20-4=$

$20-5=$

## Műveletek gyakorlása 20-ig

a)

$5+6=$	$9+7=$	$12+5=$	$2+18=$
$5+9=$	$5+6=$	$12+7=$	$5+14=$
$4+8=$	$3+7=$	$14+2=$	$3+14=$
$1+9=$	$6+8=$	$13+6=$	$2+12=$
$9+8=$	$3+9=$	$16+4=$	$1+19=$
$8+8=$	$2+8=$	$15+5=$	$4+16=$
$6+7=$	$5+5=$	$12+8=$	$7+12=$
$4+7=$	$4+6=$	$14+4=$	$6+14=$

b)

$12-2=$	$15-6=$	$17-2=$	$17-6=$
$16-5=$	$15-8=$	$15-5=$	$11-8=$
$13-2=$	$16-6=$	$12-2=$	$12-6=$
$11-1=$	$18-9=$	$17-9=$	$18-0=$
$18-7=$	$12-5=$	$18-8=$	$12-0=$
$16-4=$	$13-7=$	$16-7=$	$13-5=$
$14-3=$	$17-8=$	$11-3=$	$17-7=$
$19-6=$	$14-7=$	$11-6=$	$14-6=$

c)

$6+5+2=$	$8+5-2=$	$12-5+2=$
$8+4+6=$	$7+4-6=$	$14-6+8=$
$2+4+7=$	$9+4-7=$	$14-7+6=$
$3+9+4=$	$3+8-3=$	$15-8+2=$
$5+5+4=$	$5+7-4=$	$16-9+4=$
$9+5+2=$	$9+9-2=$	$19-9+5=$
$7+4+8=$	$9+4-6=$	$13-5+7=$

## Feladatok

a) $5+7=$	$12+6=$	$12-13=$
$4+8=$	$4+13=$	$13-5=$
$6+7=$	$15+4=$	$14-6=$
$2+9=$	$16+4=$	$15-9=$
$7+8=$	$7+13=$	$11-7=$
$5+6=$	$1+18=$	$19-14=$

b) $20-3=$	$20-12=$	$17-11=$
$20-6=$	$20-15=$	$16-13=$
$20-5=$	$20-17=$	$18-15=$
$20-2=$	$20-16=$	$17-13=$
$20-7=$	$20-11=$	$19-12=$
$20-9=$	$20-13=$	$15-14=$

c) $8+3=$	$13+7=$	$13-7=$
$7+6=$	$5+12=$	$15-9=$
$8+4=$	$14+5=$	$14-5=$
$6+5=$	$18+2=$	$16-9=$
$9+6=$	$6+14=$	$11-4=$
$2+9=$	$4+12=$	$17-6=$

d) $20-5=$	$20-13=$	$12-11=$
$20-9=$	$20-16=$	$15-13=$
$20-4=$	$20-19=$	$16-14=$
$20-3=$	$20-14=$	$17-15=$
$20-8=$	$20-18=$	$18-12=$
$20-7=$	$20-10=$	$14-10=$

## Feladatok

1.

a) $9+3=$	b) $9+2=$	c) $4+9=$
$9+7=$	$8+2=$	$8+8=$
$8+4=$	$8+6=$	$8+3=$
$7+8=$	$5+9=$	$3+9=$
$9+9=$	$7+5=$	$6+8=$
$8+7=$	$5+7=$	$2+9=$
$3+8=$	$4+7=$	$9+9=$

2.

a) $14-7=$	b) $15-6=$	c) $19-3=$
$18-7=$	$14-7=$	$20-5=$
$16-6=$	$20-4=$	$17-8=$
$19-7=$	$18-9=$	$16-5=$
$17-9=$	$11-8=$	$12-7=$
$12-4=$	$20-9=$	$20-1=$

3.

a) $1+9+7=$	b) $7+3+4=$	c) $5+5+2=$
$7+3+5=$	$9+1+7=$	$3+7+2=$
$5+5+5=$	$4+6+5=$	$4+6+4=$
$2+8+5=$	$2+8+4=$	$8+2+7=$
$9+1+8=$	$6+4+7=$	$7+3+7=$
$4+6+9=$	$2+8+2=$	$5+5+7=$
$3+7+5=$	$1+9+5=$	$6+4+9=$
$8+2+6=$	$5+5+8=$	$9+1+8=$



# Osszeadás és kivonás

T= tízes E= egyes

1.

a)

	T	E
	8	
+	6	

	T	E
	7	
+	3	

	T	E
	5	
+	9	

	T	E
	7	
+	10	

	T	E
	6	
+	10	

	T	E
	10	
+		8

	T	E
	10	
+		2

	T	E
	10	
+		6

b)

	T	E
	12	
+		6

	T	E
	13	
+		2

	T	E
	14	
+		3

	T	E
		3
+	11	

	T	E
		5
+	14	

	T	E
	17	
+		2

	T	E
		4
+	15	

	T	E
	11	
+		8

c)

	T	E
	12	
+		3

	T	E
	13	
+		5

	T	E
	14	
+		2

	T	E
		7
+	11	

	T	E
		6
+	12	

	T	E
	14	
+		4

	T	E
		15
+		4

	T	E
	14	
+		0

d)

	T	E
	13	
+		7

	T	E
	11	
+		9

	T	E
		6
+	13	

	T	E
	15	
+		5

	T	E
	12	
+		8

	T	E
	19	
+		1

	T	E
	10	
+	10	

	T	E
	16	
+		4

2.

a)

	T	E
	17	
-		8

	T	E
	16	
-		6

	T	E
	15	
-		7

	T	E
	15	
-		9

	T	E
	19	
-		6

	T	E
	19	
-		4

	T	E
		13
-		5

	T	E
		12
-		3

b)

	T	E
	15	
-		12

	T	E
	17	
-		16

	T	E
	16	
-		15

	T	E
	18	
-		13

	T	E
	18	
-		16

	T	E
	16	
-		14

	T	E
	19	
-		13

	T	E
		15
-		10

c)

	T	E
	20	
-		6

	T	E
	20	
-		4

	T	E
	20	
-		2

	T	E
	20	
-		7

	T	E
	20	
-		8

	T	E
	20	
-		9

	T	E
	20	
-		1

	T	E
		20
-		3

d)

	T	E
	20	
-		13

	T	E
	20	
-		14

	T	E
	20	
-		12

	T	E
	20	
-		11

	T	E
	20	
-		17

	T	E
	20	
-		10

	T	E
	20	
-		19

	T	E
		20
-		15

# Feladatok

1. a)

$20-2=$	$9+11=$	$20-1=$	$12+8=$
$20-4=$	$8+12=$	$20-2=$	$20-4=$
$20-8=$	$7+13=$	$20-3=$	$14+3=$
$20-5=$	$8+12=$	$20-4=$	$20-9=$
$20-3=$	$7+13=$	$20-5=$	$15+2=$
$20-5=$	$6+14=$	$20-6=$	$20-4=$
$20-3=$	$5+15=$	$20-7=$	$18+2=$
$20-1=$	$4+16=$	$20-8=$	$14-3=$
$20-6=$	$3+17=$	$20-9=$	$12+7=$

b)

$3+\square=6$	$6+\square=7$	$4+\square=7$
$13+\square=16$	$16+\square=17$	$14+\square=17$
$2+\square=6$	$6+\square=9$	$7+\square=9$
$12+\square=16$	$16+\square=19$	$17+\square=19$
$4+\square=8$	$8+\square=9$	$5+\square=9$
$14+\square=18$	$18+\square=19$	$15+\square=19$
$5+\square=6$	$8+\square=10$	$4+\square=10$
$15+\square=16$	$18+\square=20$	$14+\square=20$

2.

	2	5	6	9	8	3	4	7	5	0												
+	9	5	8	5	7	4	8	9	6	3		-	12	15	16	19	18	13	14	17	15	20
													9	5	8	5	7	4	8	9	6	3

## Feladatok

1.a)  $8 + \square = 15$        $9 + \square = 15$        $12 + \square = 19$   
 $9 + \square = 16$        $8 + \square = 16$        $13 + \square = 18$   
 $4 + \square = 18$        $5 + \square = 18$        $14 + \square = 19$   
 $7 + \square = 12$        $6 + \square = 12$        $12 + \square = 14$   
 $6 + \square = 14$        $4 + \square = 14$        $13 + \square = 16$

b)  $9 + \square = 15$        $18 + \square = 19$        $10 + \square = 20$   
 $8 + \square = 15$        $17 + \square = 19$        $12 + \square = 20$   
 $9 + \square = 13$        $16 + \square = 20$        $18 + \square = 20$   
 $7 + \square = 16$        $14 + \square = 20$        $12 + \square = 19$   
 $3 + \square = 19$        $15 + \square = 20$        $11 + \square = 18$

2.a)  $14 - 4 - 2 =$        $16 - 6 - 5 =$        $19 - 9 - 8 =$   
 $18 - 8 - 4 =$        $17 - 7 - 8 =$        $19 - 9 - 6 =$   
 $16 - 6 - 3 =$        $18 - 8 - 6 =$        $18 - 8 - 5 =$   
 $12 - 2 - 5 =$        $13 - 3 - 5 =$        $18 - 8 - 7 =$   
 $17 - 7 - 4 =$        $19 - 9 - 4 =$        $17 - 7 - 2 =$

b)  $20 - 4 =$        $20 - 10 =$        $20 - 19 =$   
 $20 - 6 =$        $20 - 12 =$        $20 - 17 =$   
 $20 - 5 =$        $20 - 11 =$        $20 - 16 =$   
 $20 - 3 =$        $20 - 13 =$        $20 - 14 =$   
 $20 - 2 =$        $20 - 15 =$        $20 - 18 =$

## Feladatok

1.a)  $2 + \square = 14$

$4 + \square = 12$

$9 + \square = 12$

$8 + \square = 13$

$5 + \square = 14$

$3 + \square = 12$

$5 + \square = 13$

$9 + \square = 14$

$1 + \square = 15$

$2 + \square = 16$

$15 + \square = 16$

$14 + \square = 17$

$16 + \square = 19$

$13 + \square = 18$

$11 + \square = 13$

b)  $1 + \square = 17$

$2 + \square = 17$

$3 + \square = 17$

$4 + \square = 17$

$5 + \square = 17$

$16 + \square = 19$

$16 + \square = 17$

$16 + \square = 18$

$16 + \square = 19$

$16 + \square = 20$

$10 + \square = 10$

$13 + \square = 20$

$16 + \square = 20$

$14 + \square = 19$

$17 + \square = 18$

2.a)  $15 - 5 - 2 =$

$14 - 4 - 4 =$

$12 - 2 - 8 =$

$19 - 9 - 5 =$

$11 - 1 - 7 =$

$17 - 7 - 5 =$

$18 - 8 - 9 =$

$18 - 8 - 7 =$

$14 - 4 - 6 =$

$19 - 9 - 2 =$

$19 - 9 - 1 =$

$11 - 1 - 6 =$

$13 - 3 - 4 =$

$16 - 6 - 7 =$

$14 - 4 - 7 =$

b)  $20 - 7 =$

$20 - 8 =$

$20 - 9 =$

$20 - 5 =$

$20 - 1 =$

$20 - 17 =$

$20 - 18 =$

$20 - 19 =$

$20 - 15 =$

$20 - 11 =$

$20 - 12 =$

$20 - 10 =$

$20 - 13 =$

$20 - 16 =$



$20 - 14 =$

Hány alma van a képen? \_\_\_\_\_  
Színezd ki a rajzot!

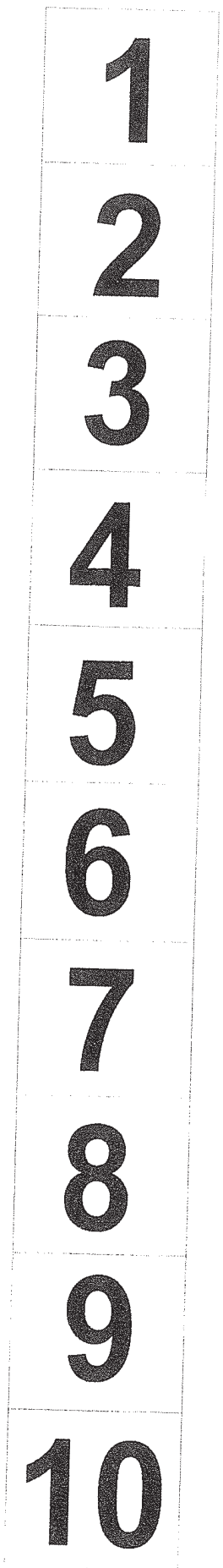
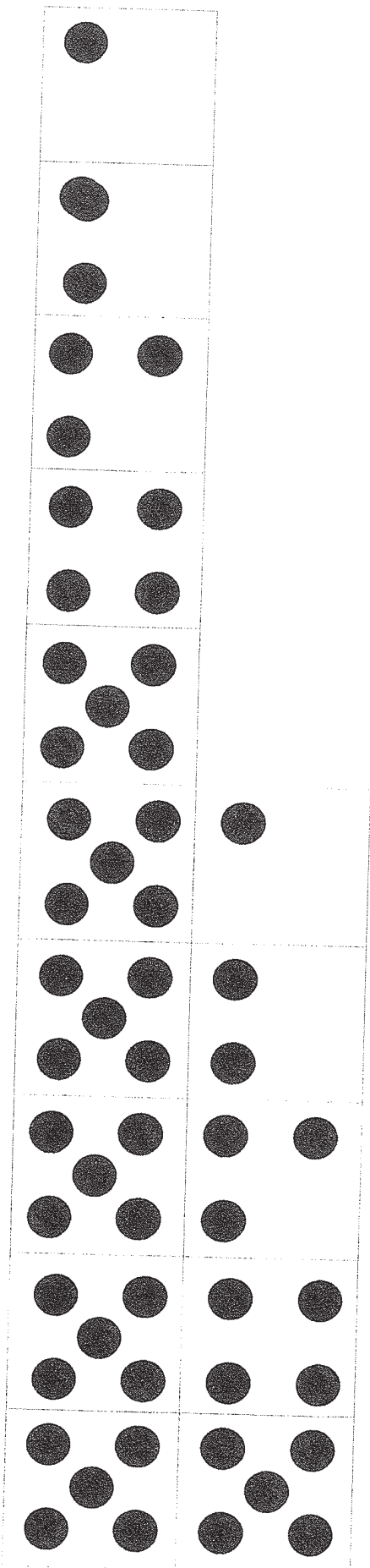

Rajzod át, vágd ki és ragaszd kartonra!  
Segítségére lehet a számolásban.

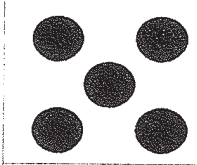
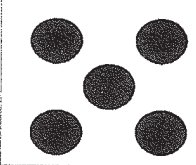

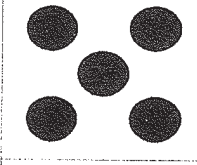
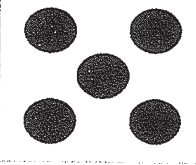
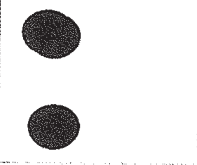
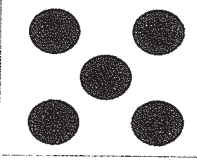
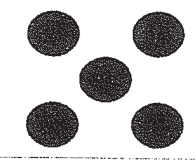
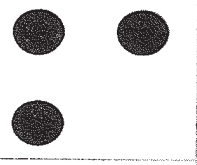
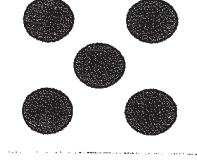
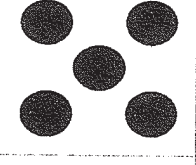
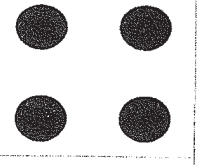
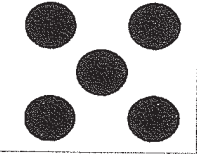
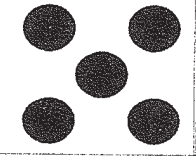
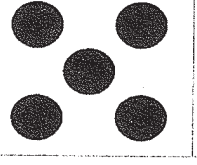
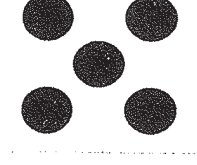
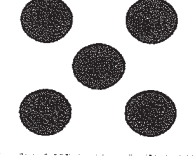
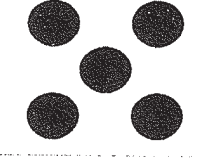
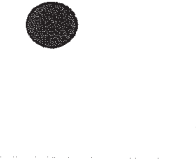
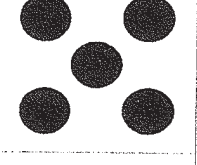
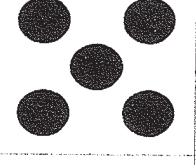
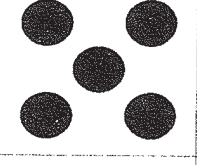
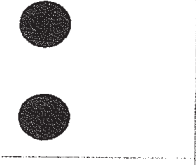
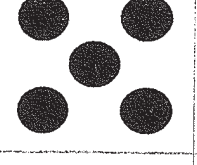
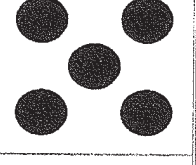
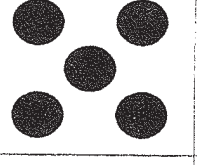
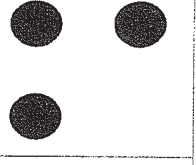
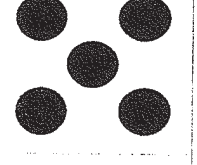
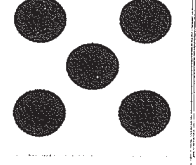
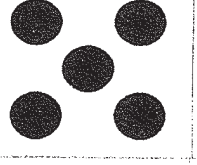
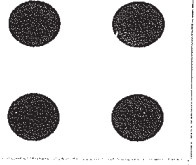
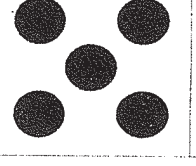
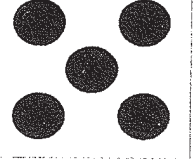
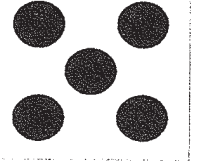
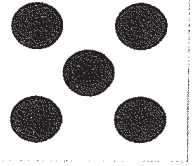
				<b>11</b>
				<b>12</b>
				<b>13</b>
				<b>14</b>
				<b>15</b>
				<b>16</b>
				<b>17</b>
				<b>18</b>
				<b>19</b>
				<b>20</b>